

## NOTICE

THIS HANDBOOK IS NOT DESIGNED, NOR CAN ANY HANDBOOK SERVE, AS A SUBSTITUTE FOR ADEQUATE AND COMPETENT FLIGHT INSTRUCTION, OR KNOWLEDGE OF THE CURRENT AIRWORTHINESS DIRECTIVES, THE APPLICABLE FEDERAL AIR REGULATIONS, AND ADVISORY CIRCULARS. IT IS NOT INTENDED TO BE A GUIDE OF BASIC FLIGHT INSTRUCTION, NOR A TRAINING MANUAL.

THE HANDBOOK IS DESIGNED:

1. TO HELP YOU OPERATE YOUR COMANCHE WITH SAFETY AND CONFIDENCE.
2. TO MORE FULLY ACQUAINT YOU WITH THE BASIC PERFORMANCE AND HANDLING CHARACTERISTICS OF THE AIRPLANE.
3. TO MORE FULLY EXPLAIN YOUR COMANCHE'S OPERATION THAN IS PERMISSIBLE TO SET FORTH IN THE AIRPLANE FLIGHT MANUAL.

IF THERE IS ANY INCONSISTENCY BETWEEN THIS HANDBOOK AND THE AIRPLANE FLIGHT MANUAL APPROVED BY THE F.A.A., THE AIRPLANE FLIGHT MANUAL SHALL GOVERN.

---

Revised text and illustrations shall be indicated by a black vertical line in the margin opposite the change.

Additional copies of this manual, Part No. 753 597, may be obtained from your Piper Dealer.

---

Published by  
PUBLICATIONS DEPARTMENT  
Piper Aircraft Corporation  
753 597  
Issued: November 1961  
Revised: November 1973

## SECTION I SPECIFICATION FEATURES

Power Plant . . . . .	1
Performance . . . . .	1
Weights . . . . .	2
Fuel . . . . .	3
Baggage . . . . .	3
Dimensions . . . . .	4
Landing Gear . . . . .	4

SPECIFICATION FEATURES:

<u>POWER PLANT</u>	<u>PA-24-180</u>	<u>PA-24-250</u>
Engine	Lyc. O-360-A1D	Lyc. O-540-A1D5
Rated Horsepower	180	250
Rated Speed RPM	2700	2575
Bore, inches	5.125	5.125
Stroke, inches	4.375	4.375
Displacement, cubic inches	361	541.5
Compression Ratio	8.5:1	8.5:1
Dry Weight, pounds	285	396
Fuel Consumption (75% power gph)	10	14
Oil Sump Capacity, quarts	8	12
Fuel Aviation Grade Octane	91/96	91/96

PERFORMANCE

Take-off Run (ft.)	750	750
Best Rate of Climb Speed (MPH)	96	105
Rate of Climb (ft. per min.)	910	1,350
Service Ceiling (ft.)	18,500	20,000
Absolute Ceiling (ft.)	21,000	22,000
Top Speed (MPH)	167	190
Cruising Speed (75% power, sea level, (MPH)	150	171
Optimum Cruising Speed, (75% power, optimum altitude)	160	181

SECTION I THE PIPER COMANCHE

SPECIFICATION FEATURES: (cont)

<u>PERFORMANCE</u>	<u>PA-24-180</u>	<u>PA-24-250</u>
Fuel Consumption (Gal. per hr., 75% power)	10	14
Cruising Range (75% sea level, std. fuel)	5 hrs, 750 mi.	4.3 hrs, 740 mi.
Cruising Range, Optimum (std. fuel)	6.2 hrs, 920 mi.	7.5 hrs, 1100 mi.
Cruising Range (75% sea level, reserve fuel)	6 hrs, 900 mi.	6.4 hrs, 1100 mi.
Cruising Range Optimum (Reserve fuel)	7.5 hrs, 1100 mi.	11.2 hrs, 1650 mi.
Stalling Speed (flaps down, MPH)	61	61
Landing Roll (flaps down, ft.)	600	650

Published figures are optimum for custom airplanes flown at gross weight under standard conditions at sea level unless otherwise stated.

<u>WEIGHTS</u>	<u>PA-24-180</u>	<u>PA-24-250</u>
Gross Weight (lbs)	2,550	2,900
Empty Weight (Standard) (lbs)	1,530	1,690

THE PIPER COMANCHE SECTION I

SPECIFICATION FEATURES: (cont)

<u>WEIGHTS</u>	<u>PA-24-180</u>	<u>PA-24-250</u>
USEFUL LOAD (Standard) (lbs)	1,020	1,210
Empty Weight (Custom) (lbs)	1,550	1,700
USEFUL LOAD (Custom) (lbs)	1,000	1,200
Empty Weight (Super Custom) (lbs)	1,570	1,755
USEFUL LOAD (Super Custom) (lbs)	980	1,165

FUEL

Fuel Capacity (Standard) (gal)	50	60
Fuel Capacity (With Reserve Fuel) (gal)	60	90
Oil Capacity (qts)	8	12

BAGGAGE

Maximum Baggage (lbs)	200	200
Baggage Door Size	20 in. x 20 in.	20 in. x 20 in.
Baggage Compart- ment Size	20 cubic ft.	20 cubic ft.

SECTION I

THE PIPER COMANCHE

SPECIFICATION FEATURES: (cont)

<u>DIMENSIONS</u>	<u>PA-24-180</u>	<u>PA-24-250</u>
Wing Span (ft)	36	36
Wing Area (sq. ft.)	178	178
Wing Loading (lbs. per sq. ft.)	14.3	16.3
Length (ft.)	24.9	
Height (ft.)	7.3	7.3
Power Loading (lbs. per HP)	14.2	11.6

LANDING GEAR

Wheel Base (ft.)		6.5	6.5
Wheel Tread (ft.)		9.8	9.8
Tire Pressure (lbs.)	Nose	27	27
	Main	27	42

SECTION II

DESIGN INFORMATION

Engine and Propeller . . . . .	5
Structures . . . . .	6
Landing Gear . . . . .	6
Control System . . . . .	9
Fuel System . . . . .	10
Electrical System . . . . .	12
Heating and Ventilating System . . . . .	13
Instrument Panel . . . . .	15
Baggage Compartment . . . . .	16
Seats . . . . .	17

## SECTION II

## DESIGN INFORMATION

ENGINE AND PROPELLER

The Comanche PA-24-180 is equipped with a Lycoming O-360-A engine rated at 180 HP at 2700 RPM while the PA-24-250 is powered by a Lycoming O-540-A engine, developing 250 HP at 2575 RPM. Both engines are direct drive, wet sump, horizontally opposed models. The compression ratio of 8.5 to 1 and the required use of 91/96 Aviation fuel is the same for both the four cylinder 180 HP engine and the six cylinder 250 HP engine. The engines are furnished with a geared starter, 50 ampere 12 volt generator, vacuum pump drive, and carburetor air box and filter.

Exhaust gases from the engine are carried overboard through an exhaust manifold. The manifold incorporates a stainless steel muffler fitted with a heater shroud which provides heat for both the cabin interior and the carburetor heat system.

Engine cooling is accomplished without the usual cowl flaps, exhaust augmenters, or drag producing fixed cowl flanges.

There are two different models of Hartzell propellers used: the 180 Comanche carries a Model HC-92ZK-8D while the "250" utilizes the Hartzell Model HC-A2XK-1. The propeller is controlled by a governor mounted on the engine which supplies oil to the propeller through the

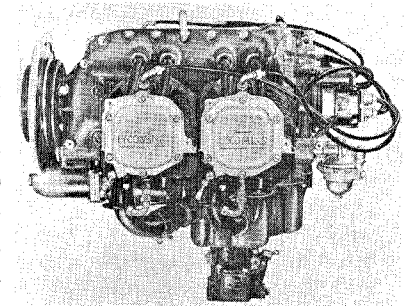

180 HP LYCOMING O-360

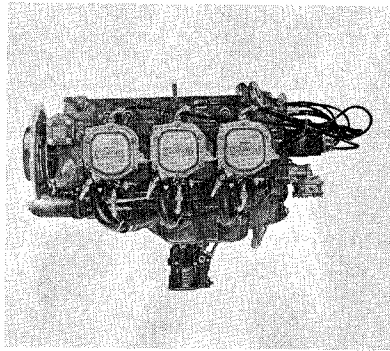

250 HP LYCOMING O-540

with acrylic lacquer.

The main spars of the wings are jointed with high strength butt fittings in the center of the fuselage, making in effect a continuous main spar. The spars are attached to the fuselage at the side of the fuselage and in the center of the structure; wings are also attached at the rear spar and at an auxiliary front spar.

The wing airfoil section is a laminar flow type, NACA-642A215, with maximum thickness about 40% aft of the landing edge. This permits the main spar, located at the point of maximum thickness, to pass through the cabin under the rear seat, providing unobstructed cabin floor space ahead of the rear seat.

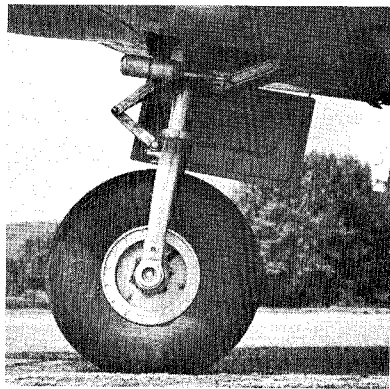

engine shaft. The governor in turn is controlled by the propeller control in the cockpit.

### STRUCTURES

Structures are of sheet aluminum construction, and are designed to ultimate load factors well in excess of normal requirements. All components are completely zinc chromate primed, exterior surfaces are coated

### LANDING GEAR

The nose gear is steerable with the rudder pedals through a 40 degree arc. During retraction of the gear the steering mechanism is

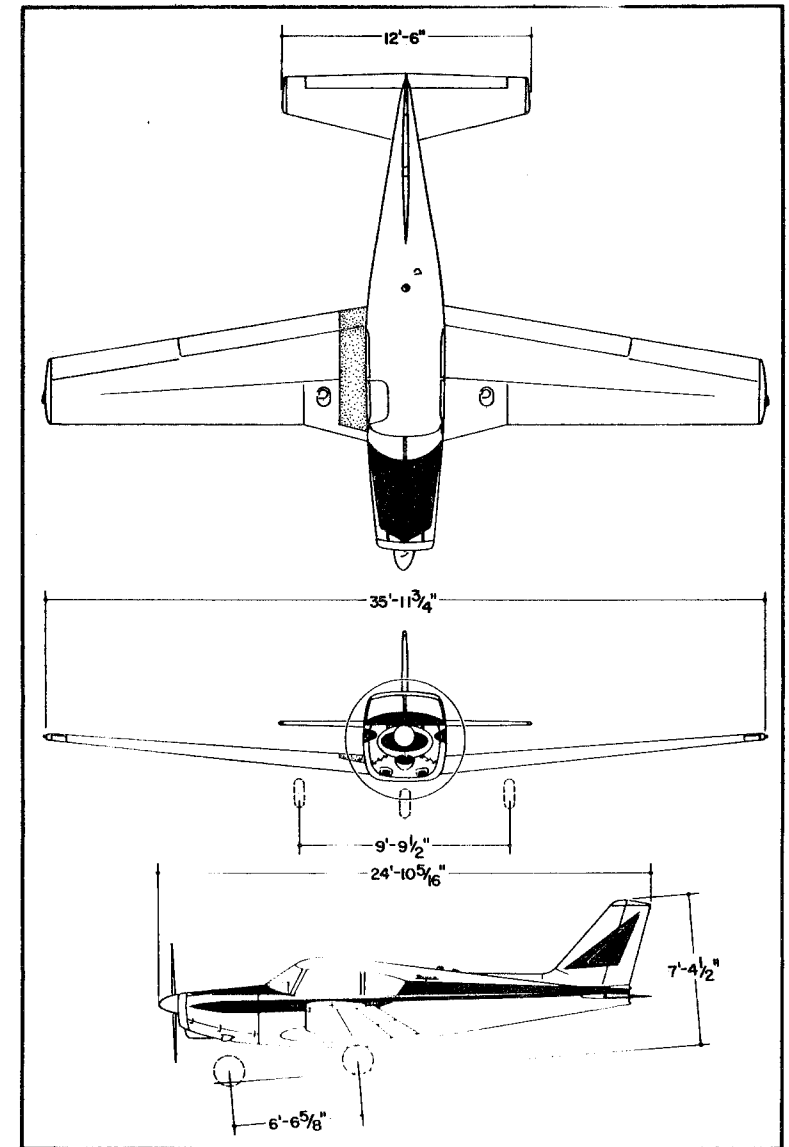

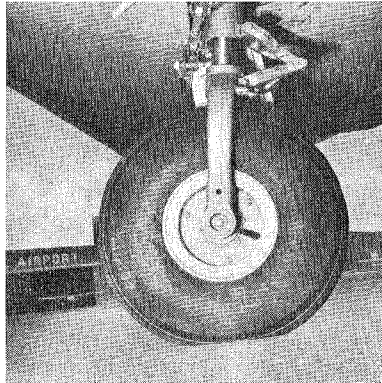

disconnected automatically to reduce rudder pedal loads in flight. The nose gear is equipped with a hydraulic-shimmy dampener.

Retraction of the landing gear is accomplished through the use of an electric motor and gear train located under the floorboards, actuating-push-pull cables to each of the gears. The landing gear motor is activated by a selector switch located on the instrument panel.

To guard against inadvertent movement of the landing gear selector on the ground, a mechanical guard is positioned just below the selector handle. The handle must also be pulled aft before moving it upward. The gear selector is in the shape of a wheel to differentiate it from the electric flap control knob, which has an airfoil shape. As an added safety feature, the warning horn is connected to the gear selector switch. The horn will then operate if the selector is moved to the "UP" position with the master switch on and the weight of the airplane is on the landing gear. As a final safety factor to prevent gear retraction on the ground, an antiretraction switch is installed on the left main gear.

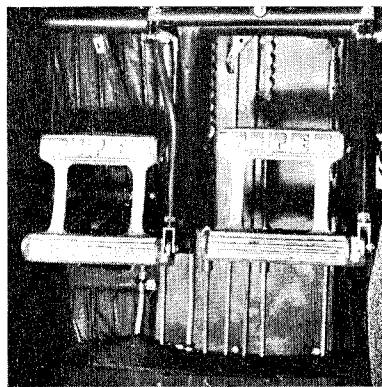

This prevents the electric circuit to the landing gear motor from being completed until the gear strut is fully extended. A green light on the instrument panel below the landing gear switch is the indication that all gears are down and locked. The warning horn will also sound if the power is reduced below approximately 12" of manifold pressure and the

gear has not been lowered. The telescoping emergency gear handle should not be used as the primary indication that the gear is down and locked. An amber light above the switch indicates gears up. THE INDICATION LIGHTS ARE AUTOMATICALLY DIMMED WHEN THE NAVIGATION LIGHTS ARE TURNED ON.

The brakes on the Comanche are actuated by toe brake pedals mounted on the left set of rudder pedals or by a hand lever protruding from under the instrument panel. Hydraulic brake cylinders are located above the left rudder pedals and are accessible in the cockpit for servicing. Parking brake valves are incorporated in each cylinder. Two cables extending from the parking brake "T" handle are attached to the parking brake valves. To prevent inadvertent application of the parking brake in flight, a safety lock is incorporated in the valves thus eliminating the possibility of pulling out the "T" handle until pressure is applied by use of the toe brakes or the hand lever.

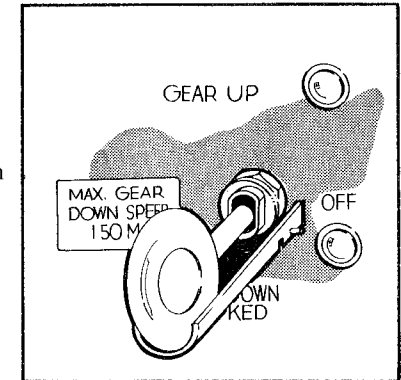

#### CONTROL SYSTEM

The flight controls on the Comanche are the conventional three control type operated by a control column and rudder pedals. The all movable stabilator, with an anti-servo tab which also acts as a longitudinal trim tab, provides extra stability and controllability with less size drag and weight.

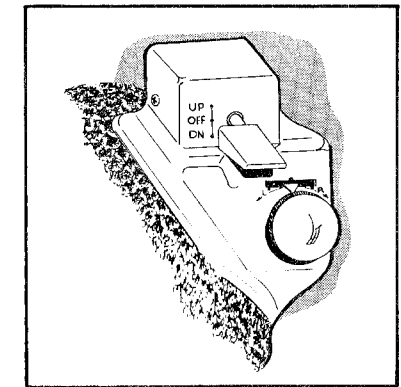

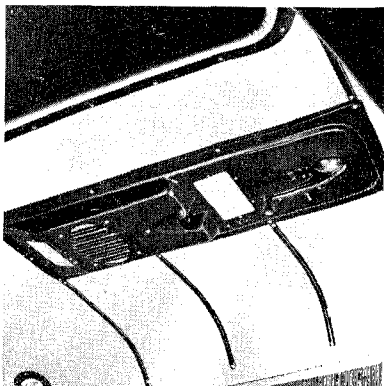

Provision for directional and longitudinal trim is provided by an adjustable trim mechanism for the rudder and stabilator. Dual flight controls are installed in the Comanche as standard equipment. A hand brake is provided to operate the brakes while occupying the right seat.

The flaps on the Comanche 180 are mechanically operated and can be positioned in three locations of 9°, 18°, and 27°. Locks on the inboard ends of the flaps hold them in the "UP" position so that the right flap can be stepped on for entry or exit. A second lock is incorporated on the Comanche 250 to prevent the flap from going full down in case a step load is applied and the full up lock was not fully engaged.

Installed on the Comanche 250 are electrically operated Max-Lift flaps. As the flaps are operated by an electric motor they can be lowered and stopped in any desired position. The flap control switch is located on the nose wheel well just above the rudder trim control. Located on the instrument panel is a flap position indicator which is marked to show the degrees of flap travel. A range for take-off operation is also shown.

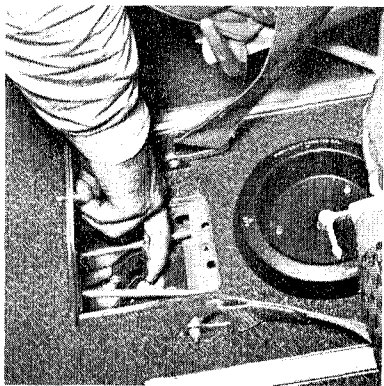

#### FUEL SYSTEM

The fuel for the Comanche is carried in two rubber-like fuel cells located in the inboard leading edge sections of the wings. Capacity of these cells, which are classified as the main

fuel cells, are 30 gallons each. On the 180 Comanche 50 gallons of fuel is called out as the standard fuel capacity. To obtain this amount of fuel it is necessary to fill the cells only to the bottom of the filler neck. To obtain the standard fuel load plus reserve quantity the cells are filled to the top of the filler neck. This system provides a reserve fuel capacity for the 180 Comanche without the necessity for extra cells. On the 250 Comanche 60 gallons is the standard fuel capacity of which 56 gallons is usable; however, if auxiliary fuel cells are installed the fuel capacity is increased to 90 gallons of which 86 gallons is usable.

As optional equipment for the Comanche 250 only, a 30 gallon auxiliary fuel system is available. The system consists of two 15 gallon fuel cells installed in the wings just outboard of the main fuel cells. Use auxiliary fuel in level flight only.

The cells should be kept full of fuel during storage of the airplane to prevent accumulation of moisture and deterioration of the cells. For long term storage without fuel, the cells should be coated with light engine oil to keep the rubber from drying out.

During normal operation the fuel is drawn to the engine from the cells by a mechanically operated fuel pump located on the engine accessory section. In the event the engine driven fuel pump fails an electric auxiliary fuel pump is provided. This pump is operated during starting, take-offs, and landings. Two auxiliary pumps are used on the Comanche 250.

The fuel strainer unit for the system is located under the floorboard in the center section of the fuselage. Daily draining of the strainer is accomplished in the cockpit by opening the hinged access door located in the floorboard just aft of the fuel

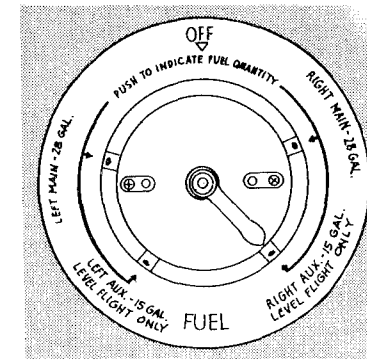

Fuel Selector - PA-24-250



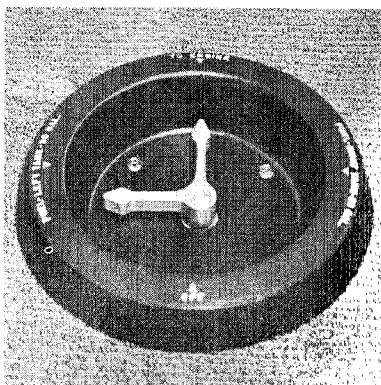

selector valve and moving the quick drain valve handle to the full aft position. The general procedure for draining the fuel system is to open the strainer quick drain for a few seconds with the fuel cell selector on one cell, then change the fuel selector to the opposite cell and repeat the process. The same process applies to the auxiliary fuel system when installed. Allow enough fuel to flow to clear the lines as well as the strainer. Positive fuel flow shut-off can be observed through the clear plastic tube which carries the fuel overboard.

Fuel quantity is indicated by an electric gauge located in the instrument cluster. The instrument is connected to a transmitter unit located in the fuel cell. On the 180 Comanche, two individual indicating systems are used, one for each main cell. The Comanche 250 incorporates only one fuel quantity gauge. This gauge will indicate the amount of fuel in the cell that is selected.

An over-ride system is incorporated so that it is possible to check the amount of fuel available in the remaining cells without moving the selector handle to that cell position. This is accomplished by depressing the red button (located on the fuel selector plate) under the desired fuel cell position. The fuel gauge will indicate the amount of fuel available in that cell. When the red button is released the indicating system will return to its normal operation.

### ELECTRICAL SYSTEM

Electrical power for the Comanche is supplied by a 12 volt, direct current system. Incorporated in the system is a 12 volt 50 ampere generator, which furnishes electrical power during

all normal operation. A 12 volt 33 ampere hour battery is used in the system to provide power for starting and as a reserve power source in case of generator failure. The battery is located behind the baggage compartment bulkhead in a sealed stainless steel battery box. Refer to the Maintenance Section for servicing of the battery.

Electrical switches and circuit breakers for the different systems are located on the lower left instrument panel. The circuit breakers automatically break the electrical circuit if an overload is applied to the system, thereby preventing damage to the component and wiring. To reset the circuit breakers simply push in the reset button. Allow approximately two minutes for breakers to cool prior to resetting. Continual popping out of a circuit breaker indicates trouble in that circuit and must be checked prior to operation. It is possible to manually trip the breaker by pulling out on the reset button.

### HEATING AND VENTILATING SYSTEM

There are four individual controls provided for regulating the heating, defrosting and ventilating air. The controls are located on the lower right side of the instrument panel in a console panel.

Heated air for the cabin interior is provided by a heater shroud attached to the exhaust muffler. Fresh air is picked up at the rear engine

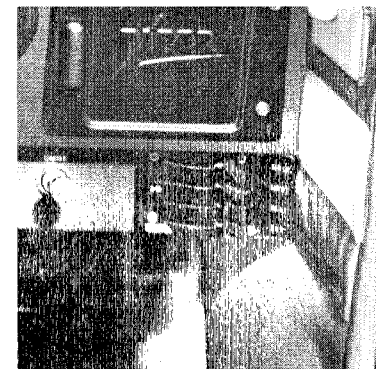
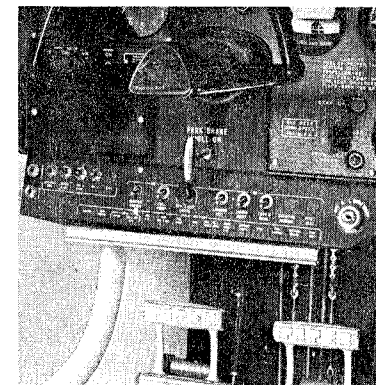

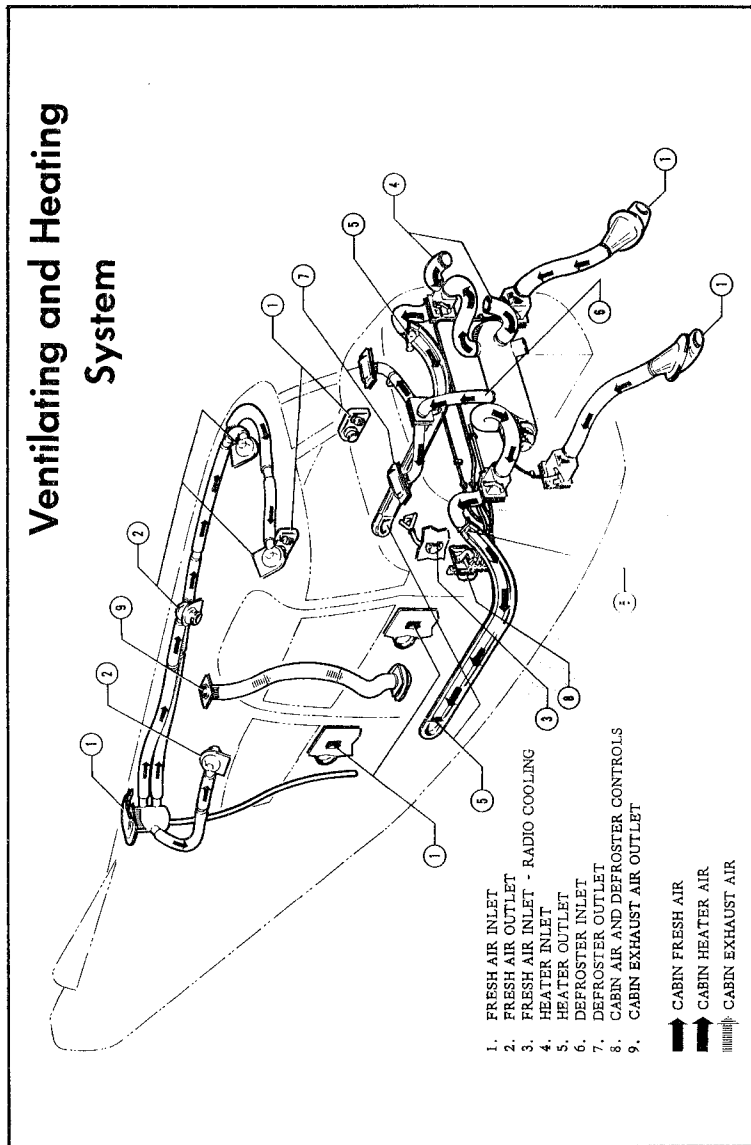

baffle and passed through the heater shroud into a control valve for distribution to the cabin.

Warm air for the defroster system is obtained directly from the heater shroud. The amount of air applied to the windshield is regulated with the control in the console. Caution should be used if it is necessary to operate the defroster on the ground as prolonged application of heat to the windshield may cause distortion.

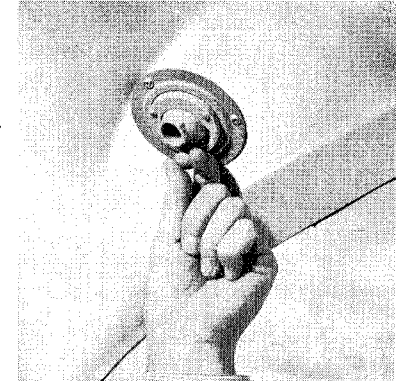

Fresh air for the cabin interior is picked up from two air scoops attached to the lower engine cowling. The air passes through flexible hoses to control valves on the firewall where the flow is regulated to the cabin. Located at each seat are two smaller air vents that may be regulated by the individual. Located in the aft section of the cabin is an exhaust vent to improve the circulation of air in the cabin interior.

#### INSTRUMENT PANEL

The instrument panel in the Comanche is designed to accommodate the customary advanced flight instruments on the left side in front of the pilot and the engine instruments on the right side. Provision for extra instruments is made in both sections. Instruments are shock mounted and are accessible for maintenance by removing a portion of the fuselage cowl over the instruments.

The Artificial Horizon and the Directional Gyro in the flight group are vacuum operated through use of a vacuum pump installed on the engine. The Turn and Bank is an electrically operated instrument and serves as a standby for the Gyro's in case of vacuum system failure.

Radio units are installed in the center of the panel. Radio power supplies are mounted aft of the baggage compartment.

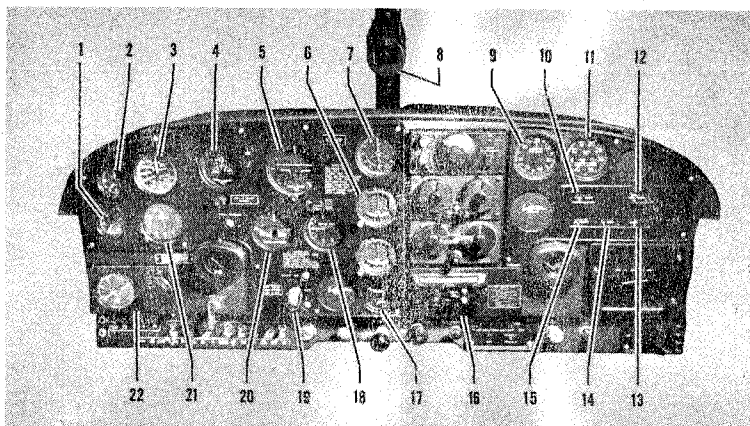

- |                            |                             |
|----------------------------|-----------------------------|
| 1. Vacuum Gauge            | 12. Fuel Pressure           |
| 2. Clock                   | 13. Ammeter                 |
| 3. Airspeed                | 14. Oil Temperature Gauge   |
| 4. Directional Gyro        | 15. Oil Pressure Gauge      |
| 5. Gyro Horizon            | 16. Altimatic Console       |
| 6. Omni Indicator          | 17. Flap Position Indicator |
| 7. ADF Indicator           | 18. Rate of Climb           |
| 8. Compass                 | 19. Landing Gear Selector   |
| 9. Manifold Pressure Gauge | 20. Turn and Bank           |
| 10. Fuel Quantity Gauge    | 21. Altimeter               |
| 11. Tachometer             | 22. Narco D.M.E.            |

### BAGGAGE COMPARTMENT

Maximum placarded weight of the baggage area is 200 pounds with 20 cubic feet of area available, accessible through a 20 x 20 inch door. Provision for securing cargo is provided by tie-down belts installed in the compartment. Attached to the top of the baggage compartment are provisions for stowing the tow bar. The key used in the ignition operates the lock on the baggage compartment door.

### SEATS

Front seats are adjustable so as to provide comfort and facilitate ease of entry and exit from the aircraft for pilot and passengers. They are easily removed by taking out the stops at the end of the mounting tracks and sliding the seats off their tracks.

The back of the rear seat is adjusted to various fore and aft positions by use of the latches at the outboard upper corners. The entire rear seat is removed quickly by disengaging the aft seat bottom tube from its attachment clamps, detaching the latches behind the top of the seat back, removing the center safety belt bolt, then lifting both the seat and the back as one unit from the cockpit.

SECTION III

OPERATING INSTRUCTIONS

Preflight . . . . .	18
Starting Engine . . . . .	19
Warm-up and Ground Check . . . . .	20
Takeoff . . . . .	21
Climb . . . . .	24
Cruising . . . . .	25
Stalls . . . . .	26
Approach and Landing . . . . .	29
Emergency Procedures . . . . .	30
Manual Gear Extension . . . . .	30
Gear-up Landing . . . . .	32
Engine Failure . . . . .	32
Mooring . . . . .	32
Operating Tips . . . . .	33
Weight and Balance . . . . .	33b

## SECTION III

## OPERATING INSTRUCTIONS

PREFLIGHT

The following safety procedure instructions must become an integral part of the aircraft owner's operational routine and preflight inspection.

Before each flight, visually inspect the airplane and determine that:

1. a. Ignition and battery switches "OFF".
2. a. There is no external damage or operational interference to the control surfaces, wings, or fuselage.  
b. There is no snow, ice, or frost on the wings or control surfaces.
3. a. Check the fuel supply.  
b. Check fuel tank caps and covers for security. (Adjust

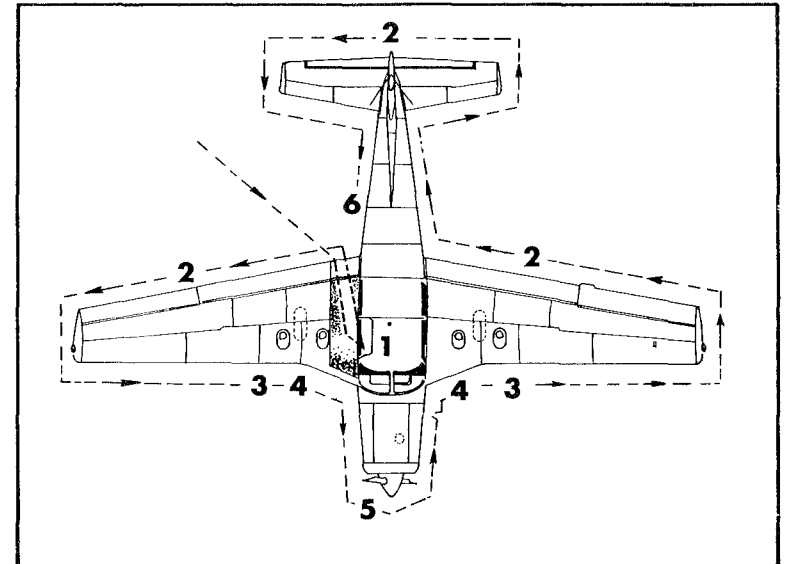

## SECTION III

## OPERATING INSTRUCTIONS

PREFLIGHT

The following safety procedure instructions must become an integral part of the aircraft owner's operational routine and preflight inspection.

Before each flight, visually inspect the airplane and determine that:

1. a. Ignition and battery switches "OFF".
2. a. There is no external damage or operational interference to the control surfaces, wings, or fuselage.  
b. There is no snow, ice, or frost on the wings or control surfaces.
3. a. Check the fuel supply.  
b. Check fuel tank caps and covers for security. (Adjust

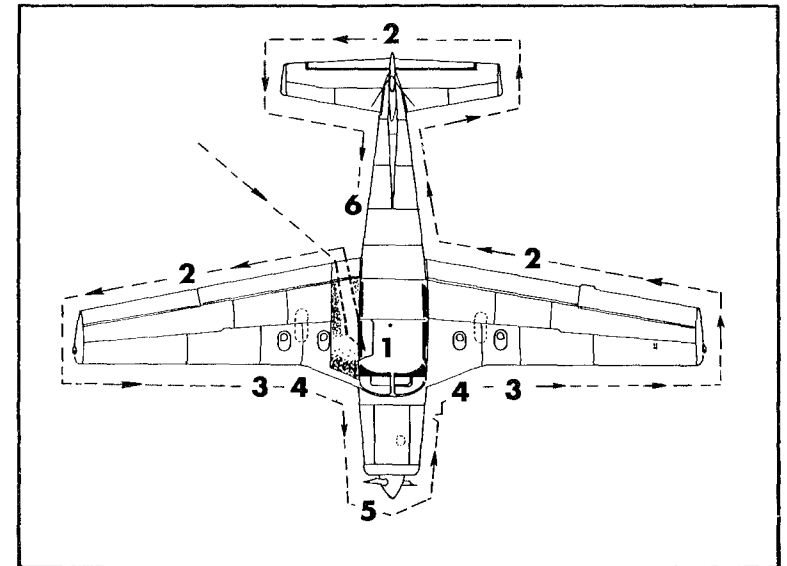

caps to maintain tight seal.)

- c. The fuel system vents are open.
4. a. The landing gear shock struts are properly inflated (approximately 2-3/4" of piston exposed).
  - b. The tires are satisfactorily inflated and not excessively worn.
5. a. The cowling and inspection covers are secured.
  - b. The windshield is clean and free of defects.
  - c. The propeller is free of detrimental nicks.
  - d. The ground area under propeller is free of loose stones, cinders, etc.
  - e. There are no obvious fuel or oil leaks.
  - f. The engine oil is at the proper level.
6. a. The tow-bar and control locks are detached and properly stowed.
7. a. Upon entering the airplane, ascertain that all controls operate normally.
  - b. Check that the landing gear selector and other controls are in their proper position.
  - c. Close and secure the cabin door.
  - d. Check that required papers are in order and in the airplane.
  - e. Drain the fuel strainer located under the floorboard aft of the fuel selector.

#### STARTING ENGINE

1. Fuel selector to the proper tank.
2. Mixture control full in, "RICH" position.
3. Carburetor heat control full in, "COLD" position.
4. Throttle open 1/4 inch.
5. Propeller control full in "INCREASE RPM".
6. Turn master switch to "ON" position.
7. Turn the auxiliary fuel pump switch "ON", listen for pump to operate and note fuel pressure indication.
8. Prime. When engine is cold (under 40° F) prime three to five strokes, if engine is warm do not prime. (Auxiliary fuel pump must be operating in order for the primer to operate.)

#### NOTE

If the engine is extremely cold, prime three to five strokes then pull the propeller through by hand. Insure the ignition switch is "OFF".

9. Check all radios for being "OFF".
10. Check the propeller area for being "CLEAR".
11. Turn the ignition switch to the "START" position and hold until engine starts. (Limit starter operation to 30 seconds) When the switch is released it will return to the "BOTH" position.

#### NOTE

If the above procedure does not start the engine reprime and repeat the process. If the engine is overprimed, open the throttle and turn the engine over with the starter. If the engine still fails to operate, check for malfunctioning of ignition or fuel system.

#### WARM-UP AND GROUND CHECK

As soon as the engine starts, the oil pressure should be checked. If no pressure is indicated within thirty seconds, stop the engine and determine the trouble. In cold weather it will take a few seconds longer to get an oil pressure indication.

Warm-up the engine at 800 to 1200 RPM for not more than two minutes in warm weather, four minutes in cold weather. If electrical power is needed from the generator, the engine can be warmed up at 1200 RPM at which point the generator cuts in. The magnetos should be checked at 2000 RPM, the drop not to exceed 125 RPM with manifold pressure of 15" HG. The engine is warm enough for take-off when the throttle can be opened without the engine faltering.

Carburetor heat should be checked during the warm-up to make sure the heat control operation is satisfactory and to

clear out the carburetor if any ice has formed. It should also be checked in flight occasionally when outside air temperatures are between 20° F and 70° F to see if icing is occurring in the carburetor. In most cases when an engine loses manifold pressure without apparent cause, the use of carburetor heat will correct the condition.

When carburetor heat is applied, cold air entering the induction system is taken from a rear baffle to an exhaust pipe shroud, then to the carburetor; it is not filtered. For this reason carburetor heat should not be used on the ground in dusty conditions except momentarily during the run-up. Dust taken into the intake system can damage the engine severely, and caution must always be exercised during ground operation to prevent dust from entering the engine.

The propeller control should be moved through its normal range during the warm-up to check for proper operation, then left in the full high RPM position. During cold weather operation the propeller should be cycled a minimum of three times to insure that warm engine oil has circulated throughout the system.

During the propeller check, as during other ground operations, care must be taken not to run-up the engine with the propeller over loose stones, cinders or other objects which can be picked up by the propeller, and which frequently cause extensive damage to the propeller blades.

#### TAKE-OFF

Just before take-off the following should be checked:

1. Controls free
2. Flaps set
3. Tab set
4. Propeller set
5. Mixture rich
6. Carburetor heat off
7. Fuel on proper tank
8. Electric fuel pump on
9. Engine gauges normal
10. Door latched
11. Safety belts fastened

In a smooth, steady motion of the throttle apply full power allowing the aircraft to accelerate in the three point attitude until the control surfaces become effective. Then apply

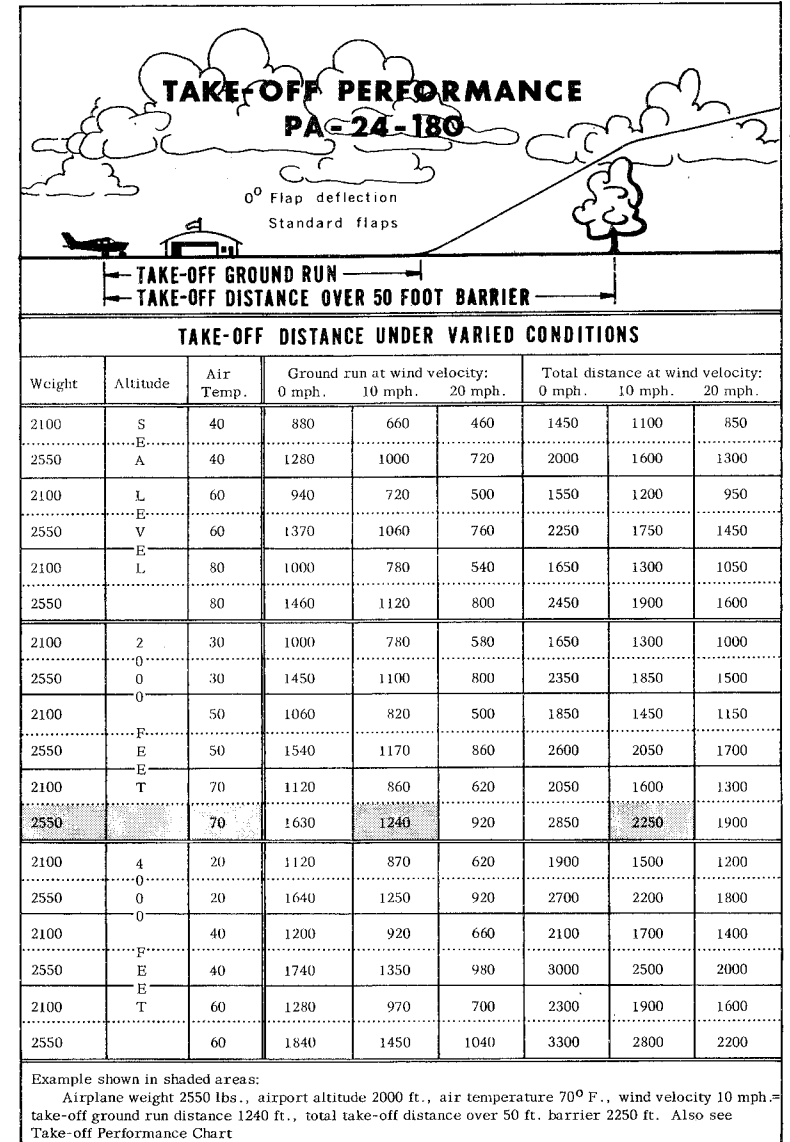



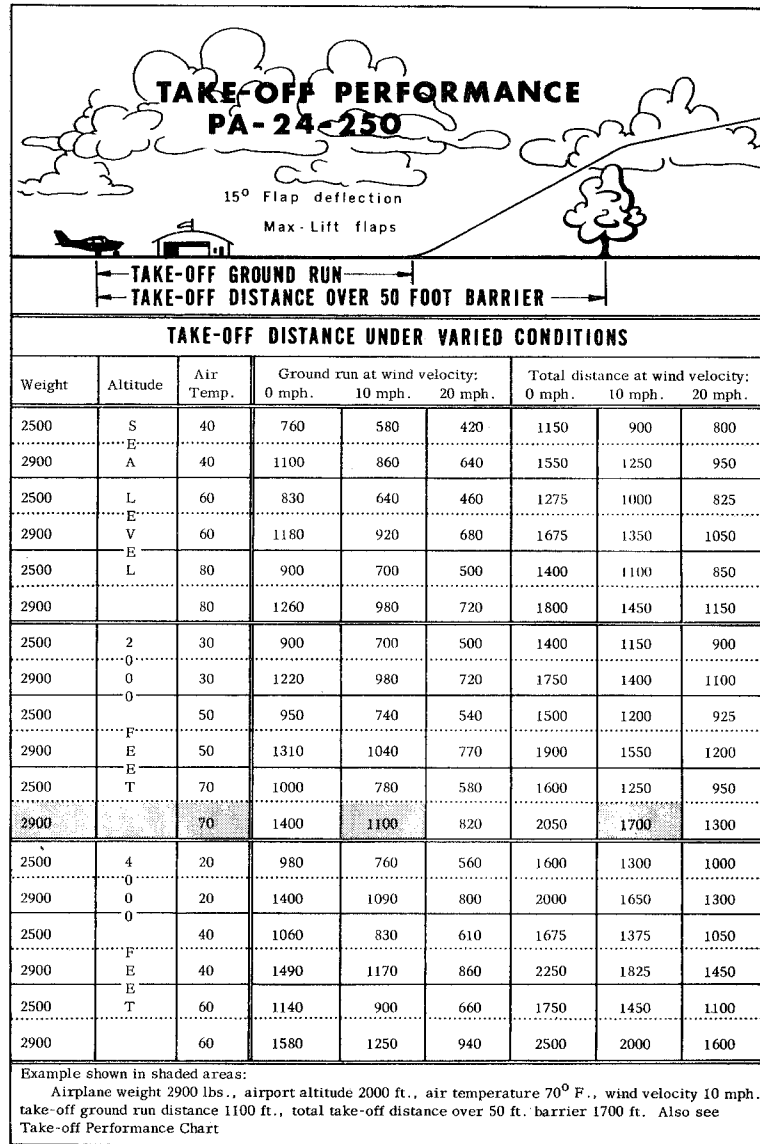

slight back pressure on the control column to lift the nose wheel. Under normal take-off conditions the Comanche will leave the ground at about 65 M.P.H. Trying to pull the aircraft off before the proper speed is obtained will only prolong the take-off run. After the take-off has proceeded to the point at which a landing could no longer be made with the wheels down in the event of power failure, the gear should be retracted. As soon as the gear is up and sufficient altitude has been gained, reduce power to climb setting.

For a minimum take-off run in the Comanche 250, the Max-Lift flaps should be lowered to the recommended 15 degrees. With the flaps in this position the take-off run will be reduced approximately 20 per cent.

Normally flaps are not used during crosswind take-offs. It is desirable to hold the nose wheel on the runway until a higher than normal take-off speed is obtained, then apply a definite but not abrupt back pressure to the control column to lift the aircraft from the runway. Once airborne, set up the required crab angle, retract the gear, and continue the climb-out.

During cold weather operation, when taking off from slush or water covered runways, allow the gear to remain down longer than usual so that any slush remaining on the gears will freeze and be broken away when the gear is retracted.

### CLIMB

The best rate of climb is obtained at 96 M.P.H. indicated airspeed at sea level on the 180, 105 M.P.H. on the 250. This speed should be decreased about 1 M.P.H. per thousand feet of altitude so that at 10,000 feet the best airspeed for maximum rate of climb is 86 M.P.H. A good rate of climb is obtained at lower altitudes at 100 to 110 M.P.H., while forward speed is increased. Reducing the climbing airspeed below 95 M.P.H. at low altitudes has the added disadvantage of cutting down forward visibility. Extended climbs at speeds below that figure are not recommended.

CRUISING

The cruising speed of the Comanche models is determined by many factors including power setting, altitude, temperature, load and equipment installed on the airplane.

For the 180 Comanche the normal cruising speed is 160 M.P.H. (T.A.S.) at 75% power at 8000 feet altitude. This power setting is obtained under standard conditions at 2400 R.P.M. and about 22" M.P. Fuel consumption at this speed approximates 10 gallons per hour. This gives a cruising range with standard fuel of 5 hours or 800 miles, and with reserve fuel 6 hours or 960 miles.

The 250 Comanche has a maximum recommended cruising speed of 181 M.P.H. at 75% power at 7000 feet, 2400 R.P.M. and 22.6" M.P. Fuel consumption at this speed approximates 14 gallons per hour. This gives a cruising range with standard fuel of 4.3 hours or 740 miles, and with auxiliary fuel cells installed a range of 6.4 hours or 1100 miles.

To keep engine wear, fuel consumption, and noise at reasonable levels, cruising R.P.M.'s from 2100 to 2400 are recommended with appropriate Manifold Pressures to obtain power settings of 65% to 75% power at low and intermediate altitudes.

With the Hartzell propeller installation on the 180 or 250, Manifold Pressures of more than 23.5" should not be used at less than 2250 R.P.M. to avoid undesirable propeller stresses. Otherwise, there are no power setting limitations.

For minimum fuel consumption and maximum efficiency, the best power settings during cruising flight are with minimum R.P.M. and the necessary Manifold Pressures to obtain a given percent of power, consistent with the above limitations. Engine smoothness and noise level should be major factors in determining the best R.P.M.

Use of the mixture control in cruising flight reduces fuel consumption significantly, especially at higher altitudes. The mixture should always be leaned during cruising operation over 5000 feet altitude, and normally also at lower altitudes at the pilot's discretion.

The continuous use of carburetor heat during cruising flight reduces power and performance. Unless icing conditions in the carburetor are severe, do not cruise with the heat on. Apply heat slowly and only for a few seconds at intervals determined by icing severity.

In order to keep the airplane in best lateral trim during cruising, the fuel should be used alternately from each tank. If auxiliary tanks are installed, it is suggested that the fuel in the two auxiliary tanks be used first.

**CAUTION**

In keeping with general practice for all aircraft, it is recommended that when flying in turbulent air or active weather such as storm conditions, that a satisfactory margin be maintained between the operating cruise speed and the Vne red line so as to allow for inadvertent speed buildups which may occur through the atmospheric conditions or distractions caused by these conditions.

STALLS

The gross weight stalling speed of the two Comanche models with full flaps and gear down is 61 M.P.H. The stall speed of the Comanche 180 increases about 5 M.P.H. with flaps and gear up. The stall speed of the Comanche 250 will increase about 9 M.P.H. in the same configuration. All controls are effective at speeds down to the stalling speed. Stalls are gentle and the airplane is easily controlled.

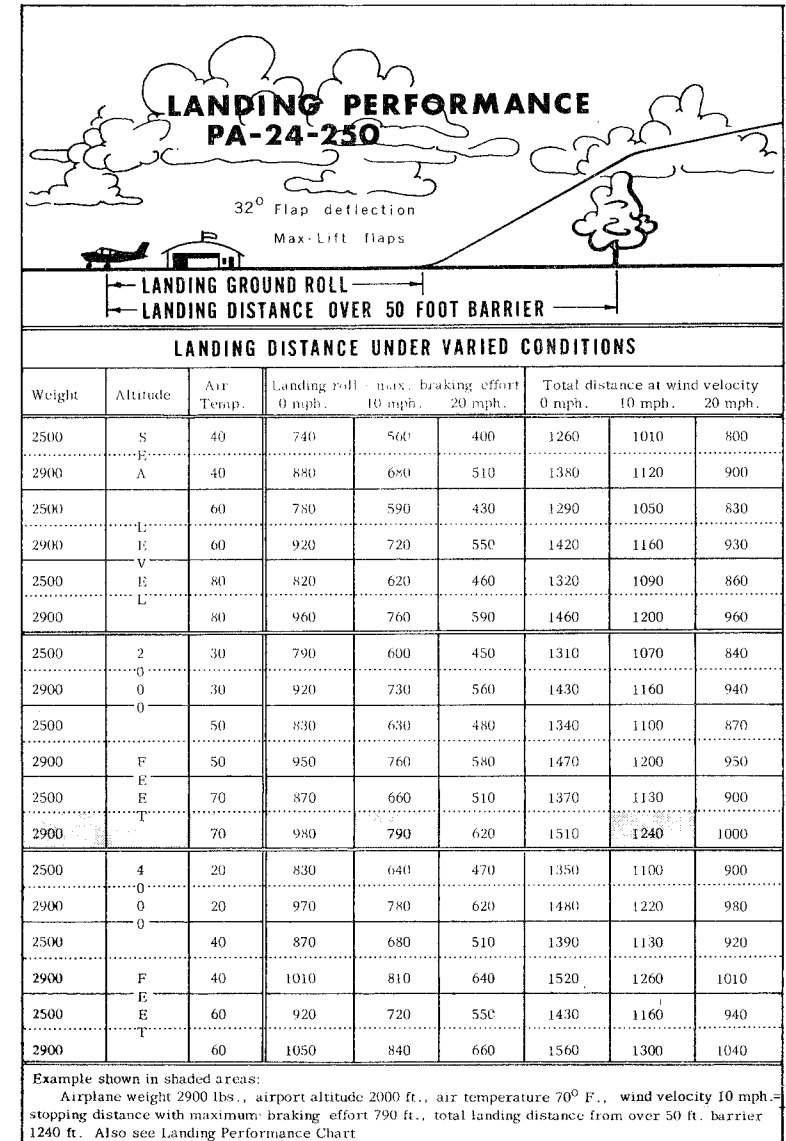
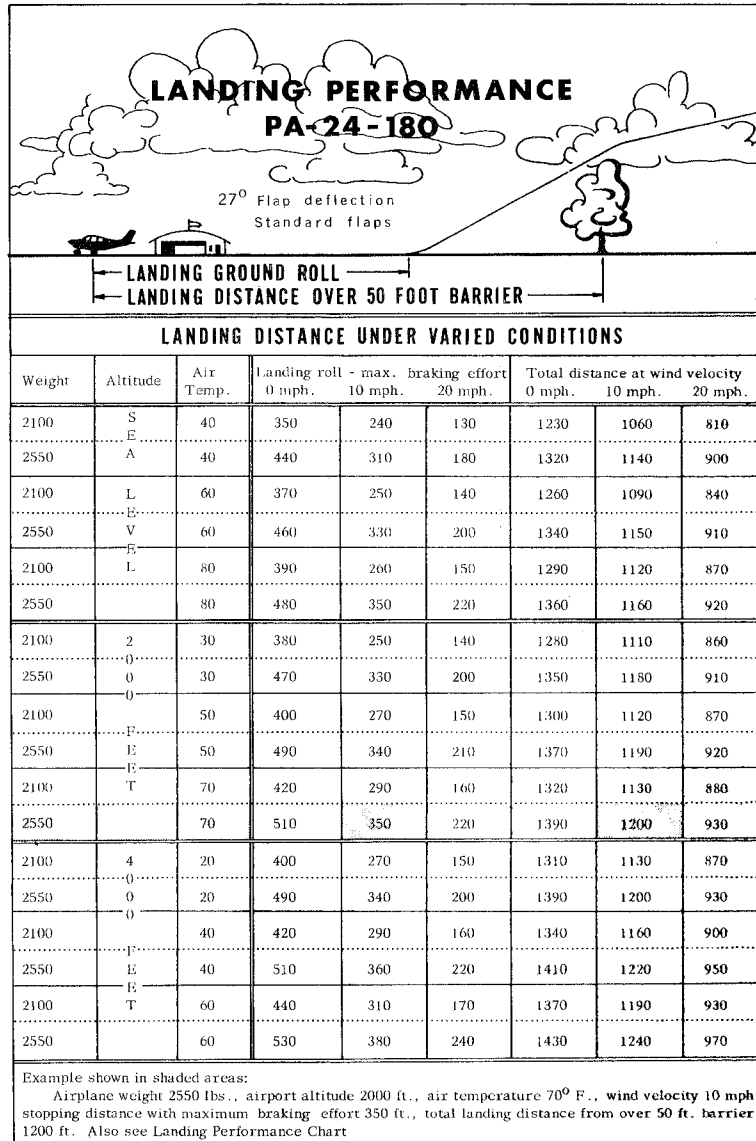

APPROACH AND LANDING

## Before Landing Check List:

1. Mixture "RICH".
2. Propeller set.
3. Carburetor heat "OFF" (unless icing conditions exist).
4. Electric fuel pump "ON".
5. Fuel selector on proper tank.
6. Landing gear "DOWN", under 150 M.P.H. (Check green light "ON", warning horn "OFF", gear emergency handle in "FORWARD" position.)
7. Flaps as desired (under 125 M.P.H.)
8. Safety belts fastened

During the approach, the landing gear can be lowered at 150 MPH or lower, preferably on the downwind leg. The flaps can be lowered at 125 MPH or below, if desired. For final approach, trim the aircraft to approximately 85 MPH (PA-24-180), 90 MPH (PA-24-250) with full flaps, or approximately 90 MPH (PA-24-180), 95 MPH (PA-24-250) with no flaps. The propeller should be set for high RPM to facilitate a go-around if required. Carburetor heat generally is not applied during landing unless icing conditions are suspected. If a landing is aborted move the carburetor heat to the off position immediately if full power is desired.

The amount of flap used during landings and the speed of the aircraft at contact should be varied according to the wind, the landing surface, and other factors. It is always best to contact the ground at the minimum practicable speed consistent with landing conditions.

Normally, the best technique for short and slow landings is to use full flap and a small amount of power, holding the nose up as long as possible before and after ground contact. In high wind conditions, particularly in strong crosswinds, it may be desirable to approach the ground at higher than normal speeds with partial or no flap.

Maximum braking effect during short field landings can be obtained by holding full back on the control wheel with flaps up while applying brakes. This forces the tail down and puts more load on the main wheels, resulting in better traction.

EMERGENCY PROCEDURES

## Manual Gear Extension:

Manual landing gear extension is accomplished with the telescoping lever located directly aft of the nose wheel housing. This control can be used only to extend the gear if the electrical actuating system has failed and not to retract the gear manually without the use of the electric motor. With the electric motor

disengaged from the gear torque tube, as required in extending the gear manually, there is no mechanism for holding the gear in the "UP" position so that the gear will not stay up if retracted manually.

To extend the gear, remove the cover over the emergency disengage control located between the two front seats, and follow the instructions on the back of this cover as follows:

1. Airspeed not over 100 M.P.H.
2. Landing gear switch in center "OFF" position.
3. Disengage electric motor by pushing motor release arm forward through full travel.
4. Extend emergency handle to full length.
5. Push handle forward full travel to extend the landing gear.

After the gear has been extended manually, do not perform any unnecessary operation to the gear until the aircraft is placed on jacks.

To return the system to normal electric operation, re-engage the electric motor to the landing gear extension torque tube by following the procedure given:

1. Landing gear switch in center "OFF" position.
2. Pull landing gear emergency extension handle about half way back, allowing gear to hang partially retracted.
3. With landing gear control switch move end of the electric motor drive shaft into position about half way back so that the slot in the drive shaft is near the mating pin on the torque tube.
4. Using the extension handle move the torque tube pin slightly back and forth until it can be engaged with the drive shaft slot, then push the parts together.

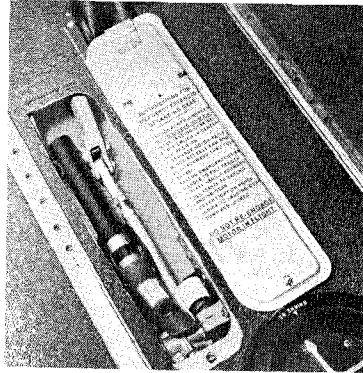

5. Lock the drive shaft to the torque tube by pulling the motor release arm full back to the normal locked position.

#### Gear-Up Landing:

A gear-up landing should only be made during an emergency (1) when the surface is too soft or rough to permit a gear down landing, (2) when a field is too short for a gear-down landing, which might cause more damage through hitting obstructions than the gear-up landing would cause, (3) when a water landing is necessary.

In the event of a gear-up landing, make a normal approach as with gear-down, leave flaps up (to reduce flap and wing damage), close the throttle and cut the master and ignition switches during the flare out, turn the fuel selector off, and contact the ground at minimum speed.

#### Engine Failure:

The most common cause of engine failure is mismanagement or malfunction of the fuel system. Therefore, the first step to take after engine failure is to move the fuel selector valve to the tank not being used. This will often keep the engine running even if there is no apparent reason for the engine to stop on the tank being used.

If changing to the opposite fuel tank does not restore the engine:

- (1) Check fuel pressure and turn on electric fuel pump, if off.
- (2) Push mixture control to full "RICH".
- (3) Apply carburetor heat.
- (4) Check ignition switch.

#### MOORING

The Comanche should be moved on the ground with the aid of the nose wheel-tow-bar provided with each plane and stored in the baggage compartment on the bottom of the hat shelf.

Tie-down ropes for mooring the airplane can be fastened to the wing tie-down rings and the tail skid.

The aileron and elevator controls should be secured by means of the safety belt to prevent control surface damage. The rudder is held in position by its connections with the steerable nose wheel and does not need to be secured except under unusually high wind conditions. The flaps are locked in position when left full "UP", so should always be retracted for mooring to prevent wind damage and permit using the flap as a step.

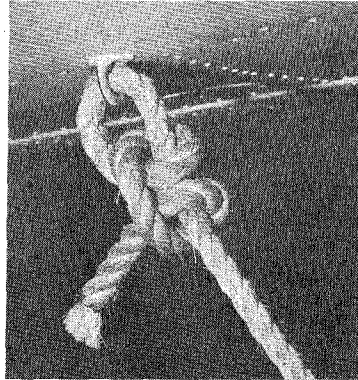

#### OPERATING TIPS

In the operation of the Comanche, as in that of any other type of aircraft, there are a few points of technique and information that apply particularly to this model. The following Operating Tips may be helpful in the operation of the Comanche:

- (1) Remember that when the navigation lights are on the gear position lights are very dim.
- (2) Learn to trim the airplane for take-off so that only a very light back pressure on the wheel is required to lift the ship off the ground.
- (3) On take-off, do not retract the gear prematurely. The aircraft may settle and make contact with the ground because of lack of flying speed, atmospheric conditions or rolling terrain.
- (4) The best speed for take-off is at about 65 M.P.H. under normal conditions. Trying to pull the airplane off the ground at too low an airspeed will increase the take-off roll rather than decrease it.
- (5) Although it is permissible to extend the landing gear at

speeds up to 150 M.P.H., the loads on the landing gear extension motor and on the gear doors are much lower if slower speeds are used. For this reason, it is recommended that unless there is good reason to lower the gear at a higher speed, it should normally be extended at speeds below 125 M.P.H.

(6) The flaps can be lowered at airspeeds up to 125 M.P.H. To reduce flap operating loads, however, it is desirable to slow the airplane to 100 M.P.H. or less before extending the flaps. At these reduced speeds, the load applied to the flaps is greatly reduced.

(7) During gear operation keep the floor area under the emergency gear lever clear. Restriction to movement of the lever will cause the gear motor circuit breaker to open.

(8) Always ascertain position of landing gear by the position of the emergency gear lever as well as the gear position lights.

(9) If, under unusual circumstances, the landing gear motor is apparently being overloaded and the circuit breaker opens repeatedly, the electric motor can be assisted by applying light hand pressure to the emergency gear lever.

(10) Before attempting to reset any circuit breaker, allow a two to five minute cooling off period.

(11) The shape of the fuel tanks is such that in certain maneuvers the fuel may move away from the tank outlet. If the outlet is uncovered, the fuel flow may be interrupted and a temporary loss of power may result. Pilot's can prevent inadvertent uncovering of the outlet by having adequate fuel in the tank selected and avoiding maneuvers which could result in uncovering the outlet.

Running turning takeoffs should be avoided as fuel flow interruption may occur.

Prolonged slips or skids in any pitch attitude or other unusual or abrupt maneuvers which could cause uncovering of the fuel outlet must be avoided.

(12) The rudder pedals are suspended from a torque tube which extends across the fuselage. The pilot should become familiar with the proper positioning of his feet on the rudder pedals so as to avoid interference with the torque tube when moving the rudder pedals or operating the toe brakes.

SECTION III

THE PIPER COMANCHE

WEIGHT AND BALANCE

For weight and balance data, see the Flight Manual and Weight and Balance form supplied with each airplane, which gives the exact weight of the airplane and permissible center of gravity conditions.

SECTION IV

PERFORMANCE CHARTS

Altitude Conversion Chart . . . . .	34
Takeoff Performance - PA-24-180 . . . . .	35
Takeoff Performance - PA-24-250 . . . . .	36
True Airspeed vs Density Altitude - PA-24-180 . . . . .	37
True Airspeed vs Density Altitude - PA-24-250 . . . . .	38
Range vs Density Altitude - PA-24-180 . . . . .	39
Range vs Density Altitude - PA-24-250 . . . . .	40
Rate of Climb vs Density Altitude - PA-24-180 . . . . .	41
Rate of Climb vs Density Altitude - PA-24-250 . . . . .	42
Landing Performance - PA-24-180 . . . . .	43
Landing Performance - PA-24-250 . . . . .	44
Power Chart - Lycoming O-360-A . . . . .	45
Power Plant - Lycoming O-540-A1D5 . . . . .	46
Power Setting Table - Lycoming Model O-360-A . . . . .	47
Power Setting Table - Lycoming Model O-540-A . . . . .	48

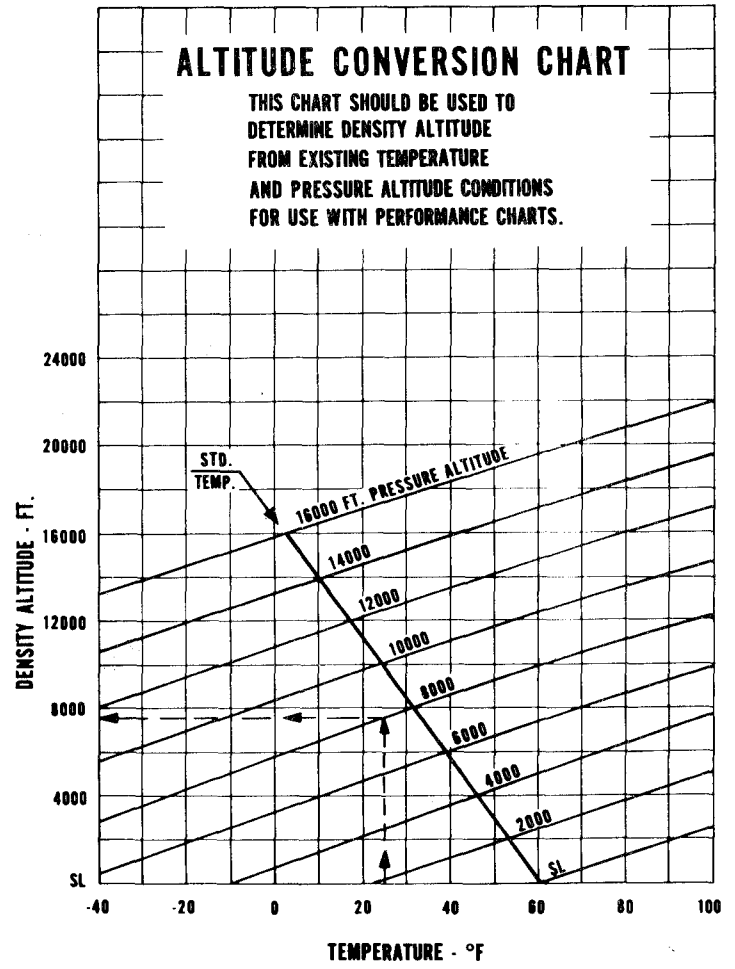



## PIPER COMANCHE PA-24-180

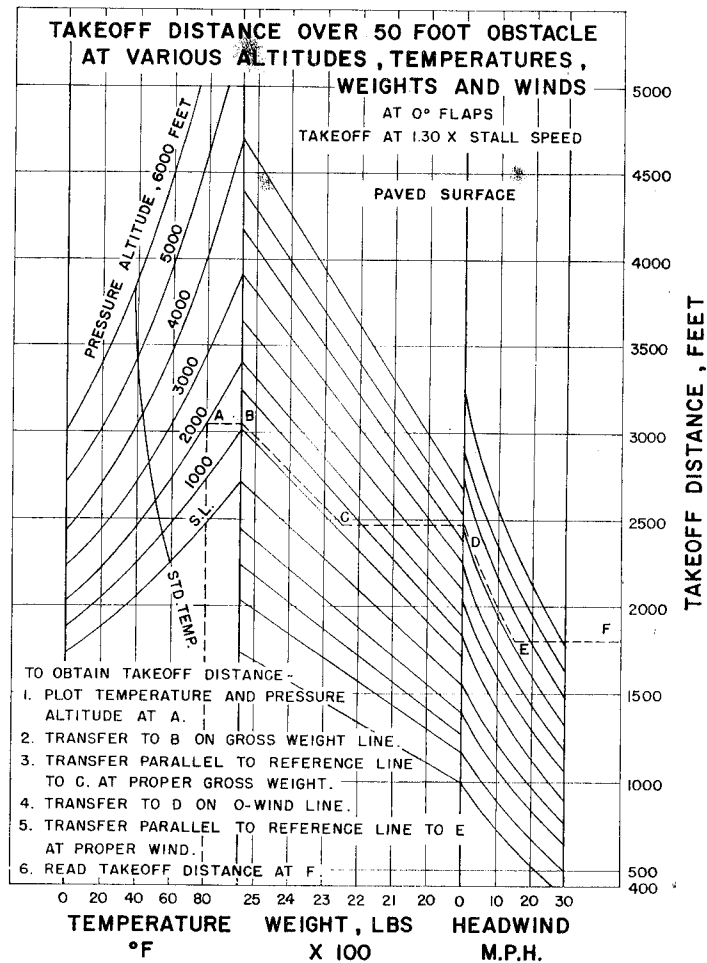

## PIPER COMANCHE PA-24-250

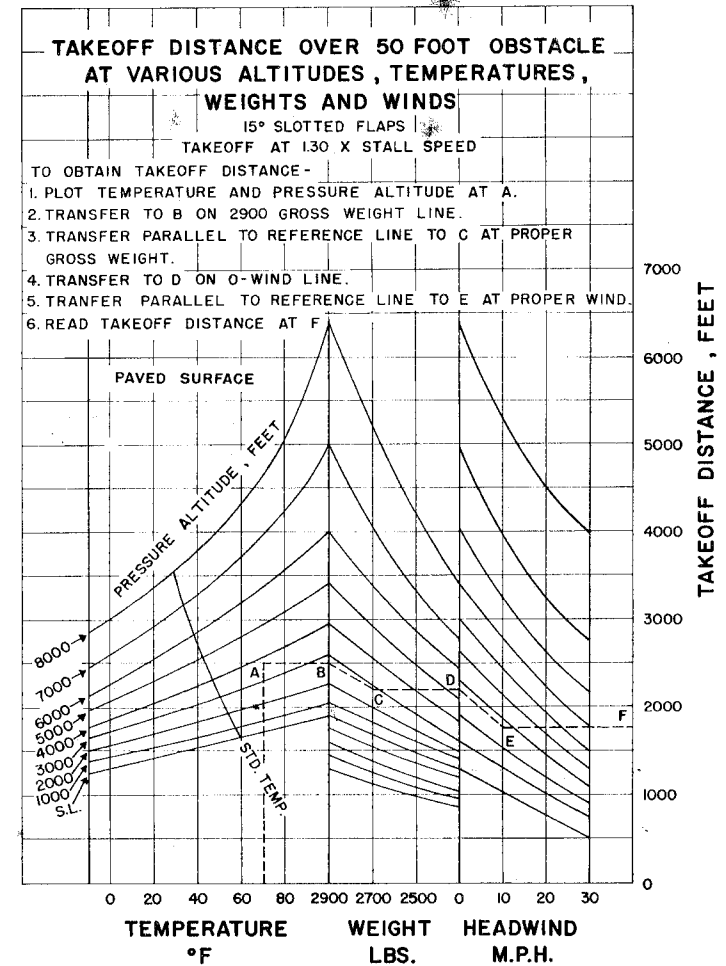

## PIPER COMANCHE PA-24-180

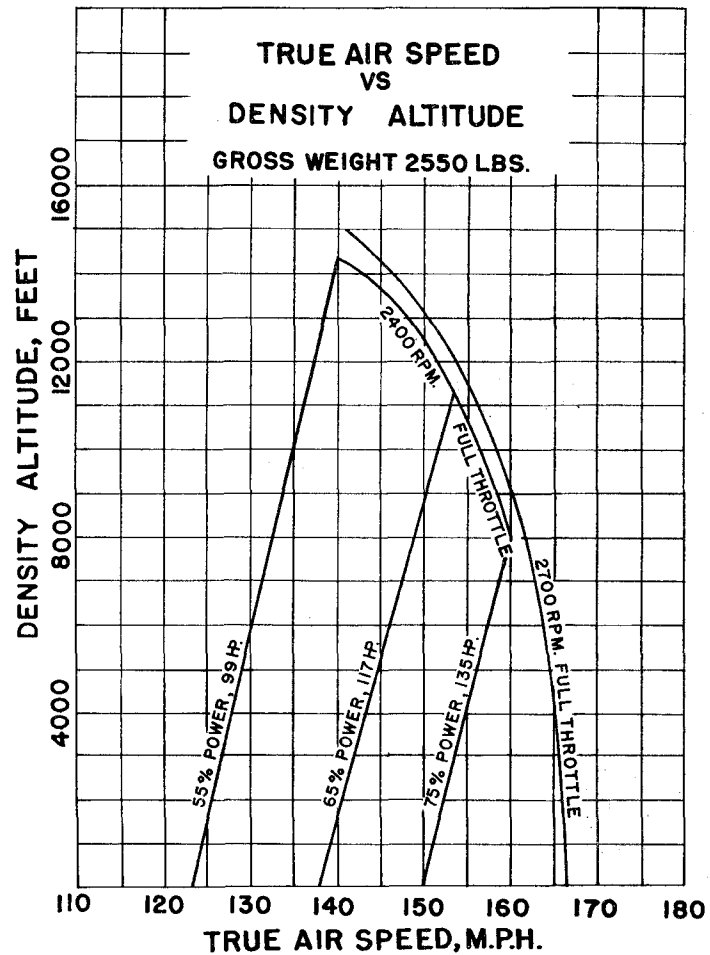

## PIPER COMANCHE PA-24-250

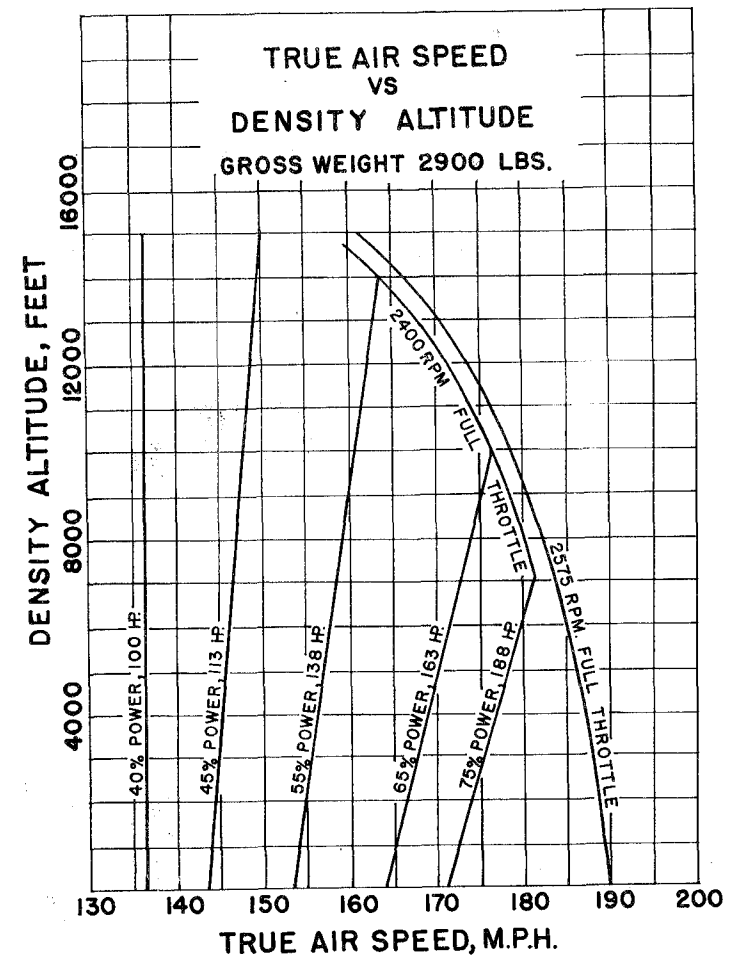

PIPER COMANCHE

PA-24-180

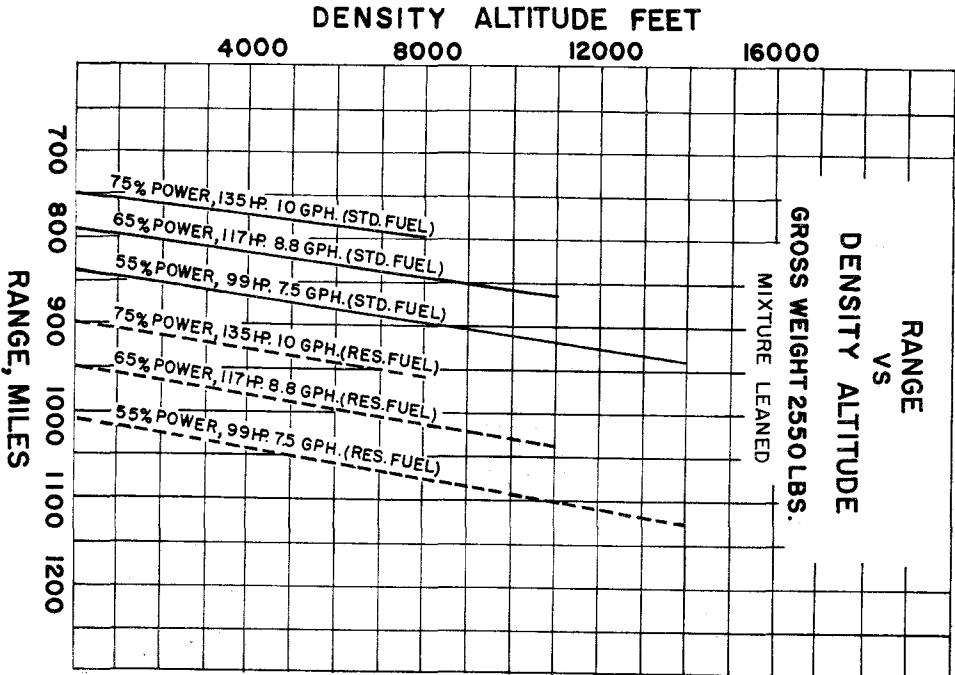

PIPER COMANCHE

PA-24-250

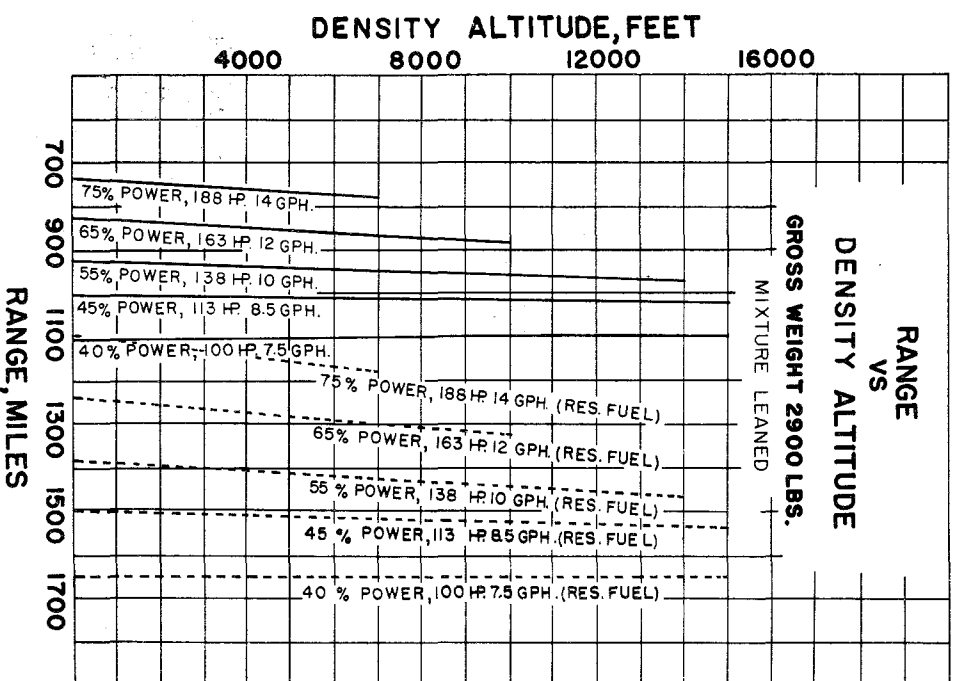

## PIPER COMANCHE PA-24-180

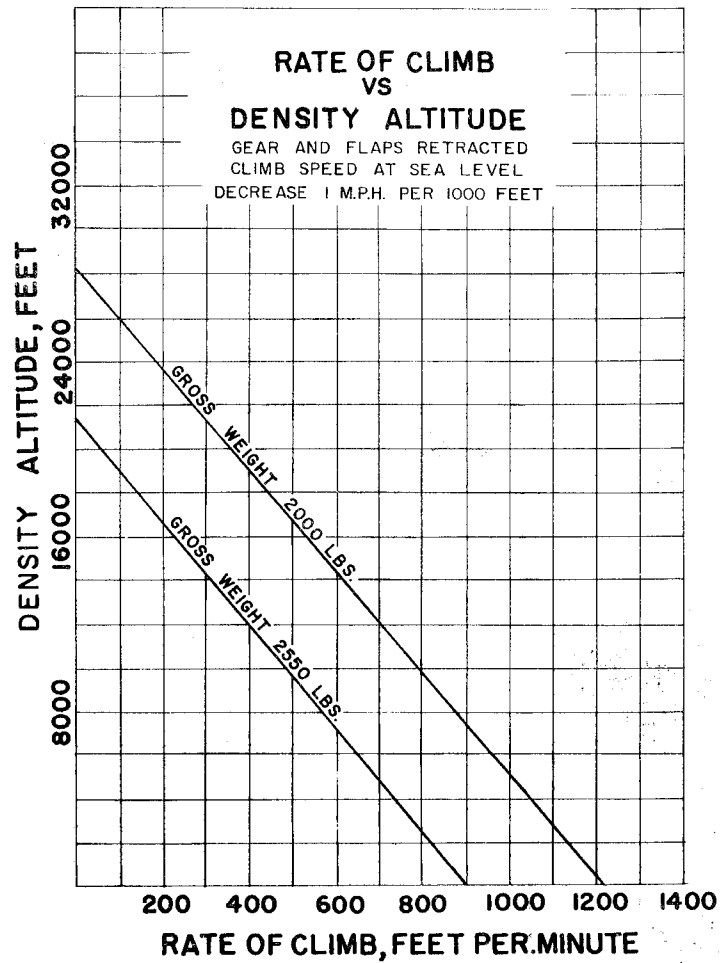

## PIPER COMANCHE PA-24-250

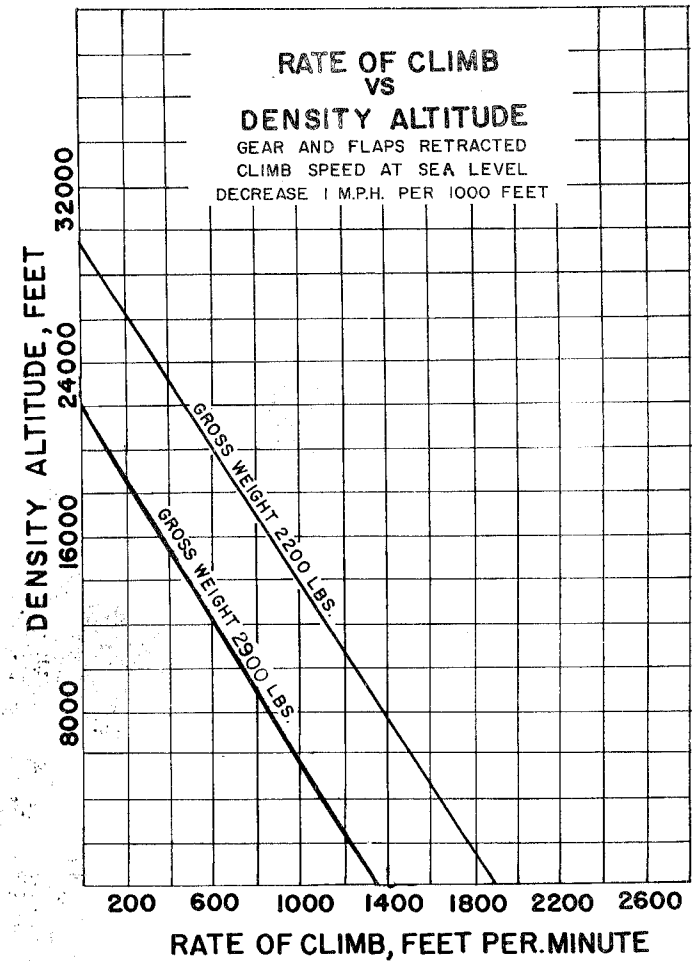

## PIPER COMANCHE PA-24-180

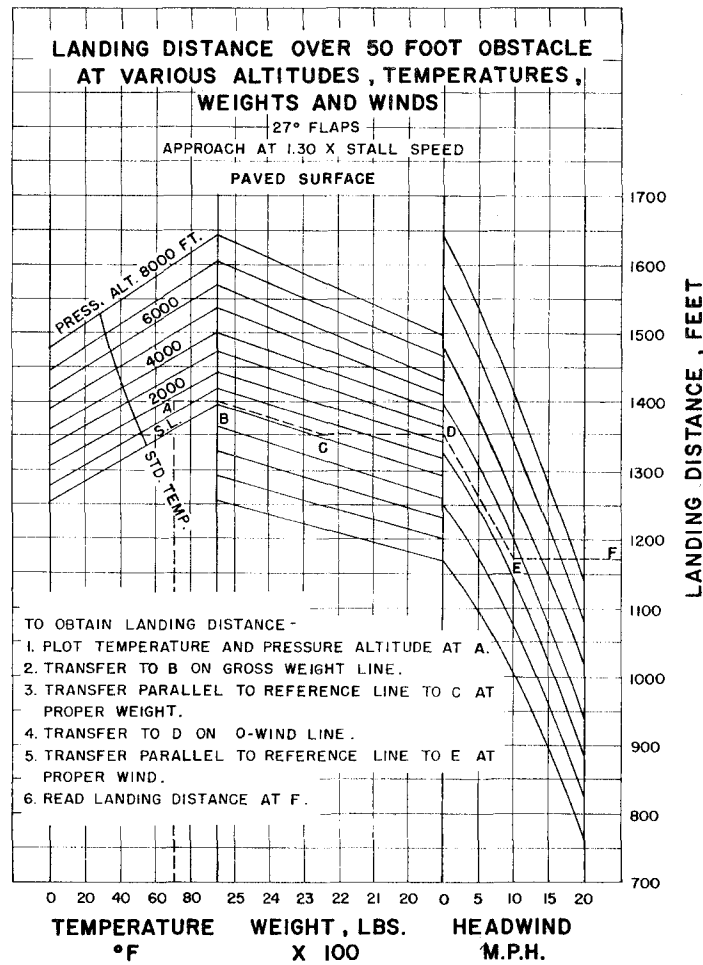

## PIPER COMANCHE PA-24-250

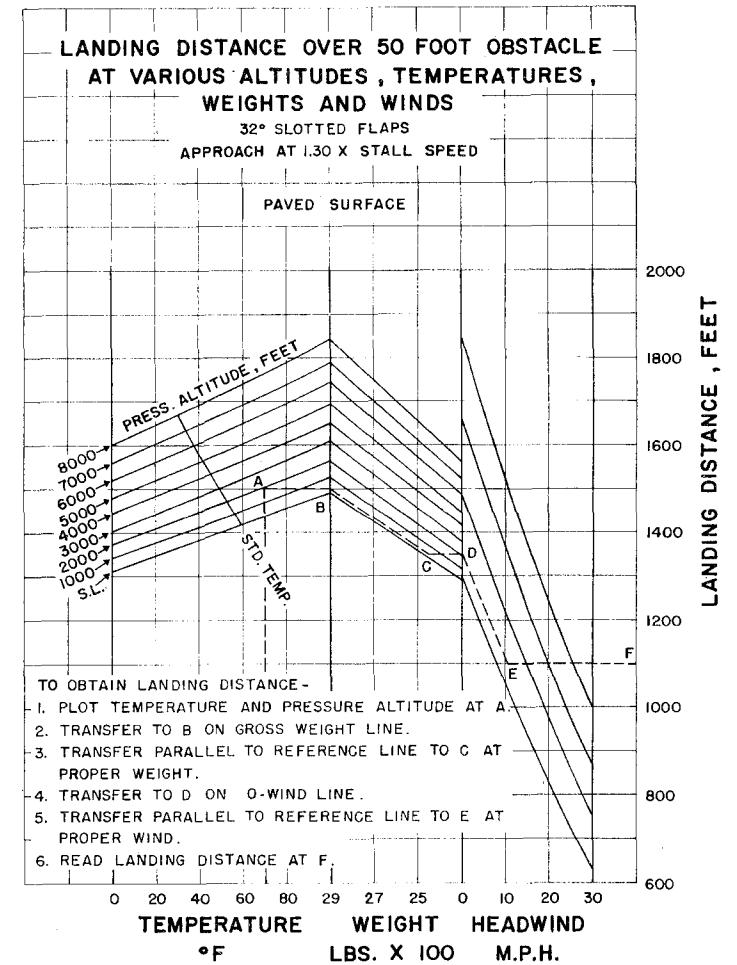

### Power Chart, Lycoming O-360-A

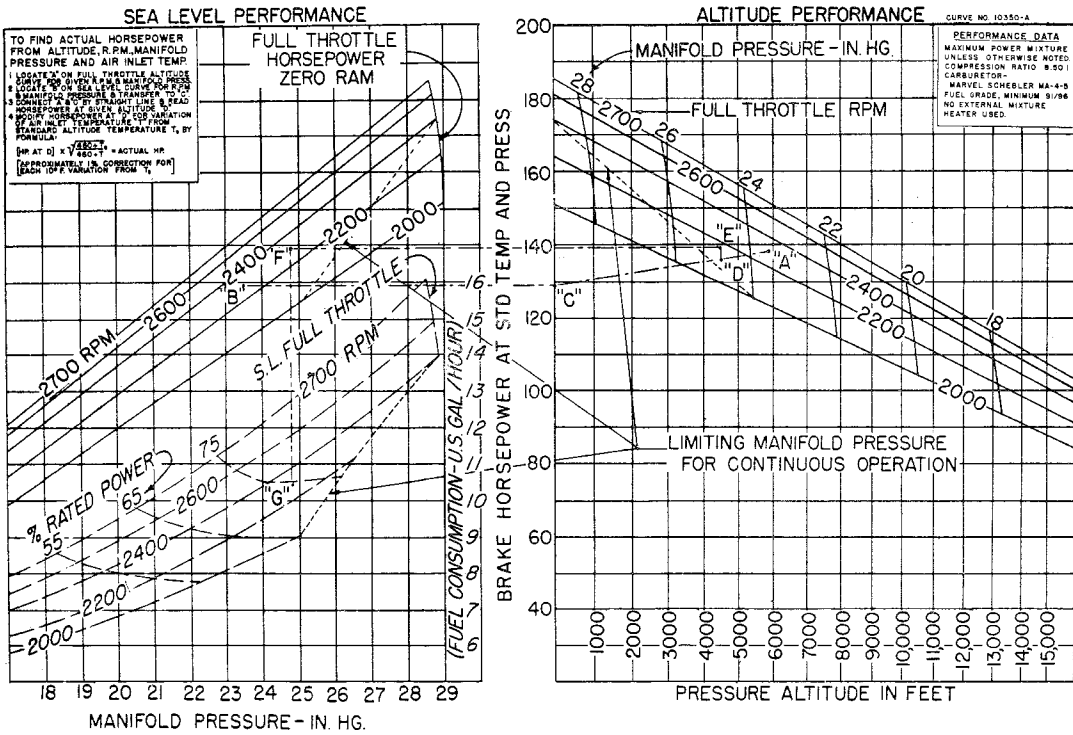

753 597  
731108

SECTION IV

THE PIPER COMANCHE

753 597  
731108

### Power Chart, Lycoming O-540-A

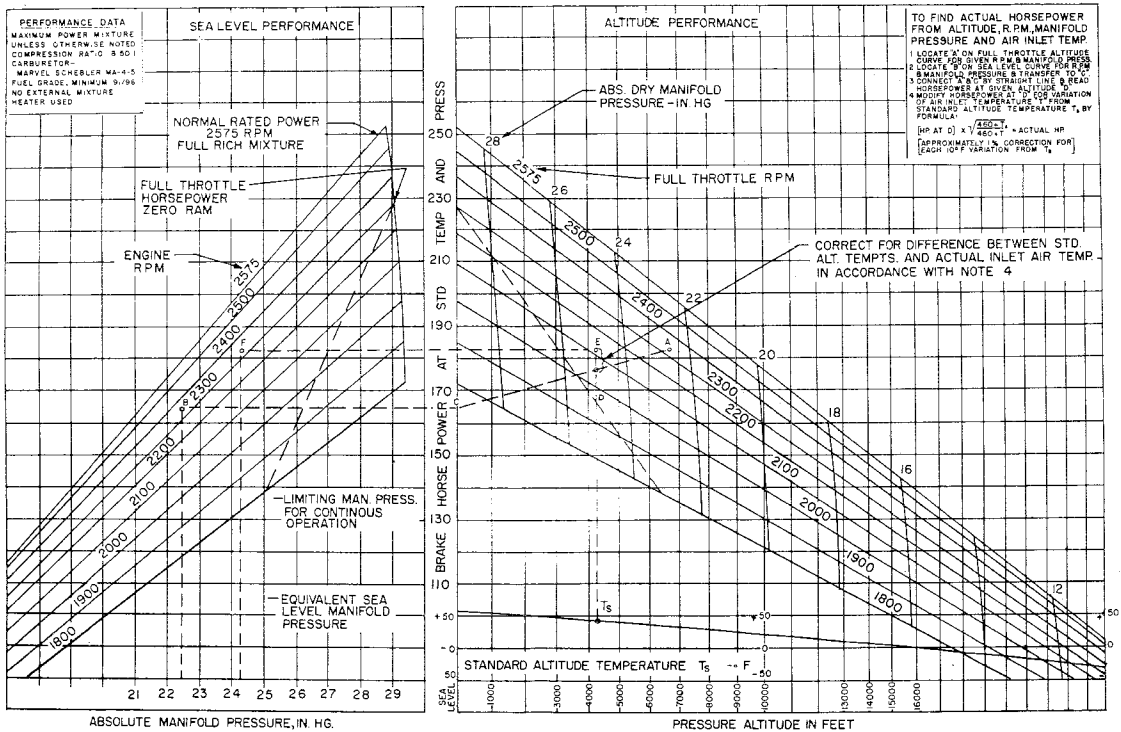

46

THE PIPER COMANCHE

SECTION IV

**Power Setting Table — Lycoming Model O-360-A, 180 HP Engine**

Press. Alt. 1000 Feet	Std. Alt. Temp. °F	99 HP — 55% Rated Approx. Fuel 7.4 Gal./Hr. RPM AND MAN. PRESS.				117 HP — 65% Rated Approx. Fuel 8.8 Gal./Hr. RPM AND MAN. PRESS.				135 HP — 75% Rated Approx. Fuel 10 Gal./Hr. RPM AND MAN. PRESS.		
		2100	2200	2300	2400	2100	2200	2300	2400	2200	2300	2400
SL	59	20.9	20.3	19.8	19.3	23.3	22.7	22.1	21.5	25.1	24.5	23.9
1	55	20.7	20.1	19.6	19.1	23.1	22.4	21.8	21.3	24.8	24.2	23.6
2	52	20.4	19.8	19.3	18.8	22.8	22.1	21.6	21.0	24.6	24.0	23.4
3	48	20.2	19.6	19.1	18.6	22.5	21.9	21.3	20.8	24.3	23.7	23.2
4	45	19.9	19.3	18.9	18.4	22.3	21.6	21.1	20.6	24.0	23.5	22.9
5	41	19.7	19.1	18.7	18.2	22.0	21.4	20.9	20.3	23.8	23.2	22.7
6	38	19.5	18.9	18.4	18.0	21.8	21.1	20.6	20.1	—	23.0	22.5
7	34	19.3	18.7	18.2	17.8	21.5	20.9	20.4	19.9	—	—	22.2
8	31	19.0	18.4	18.0	17.6	21.3	20.7	20.2	19.7	—	—	—
9	27	18.8	18.2	17.8	17.4	—	20.4	20.0	19.5	—	—	—
10	23	18.6	18.0	17.6	17.2	—	—	19.8	19.3	—	—	—
11	19	18.4	17.8	17.4	17.0	—	—	—	19.1	—	—	—
12	16	18.2	17.6	17.2	16.8	—	—	—	—	—	—	—
13	12	—	17.4	17.0	16.7	—	—	—	—	—	—	—
14	9	—	—	16.8	16.5	—	—	—	—	—	—	—
15	5	—	—	—	16.3	—	—	—	—	—	—	—

To maintain constant power, correct manifold pressure approximately 0.17" Hg for each 10° F. variation in carburetor air temperature from standard altitude temperature. Add manifold pressure for air temperatures above standard; subtract for temperatures below standard.

753 597  
731108

SECTION IV

THE PIPER COMANCHE

753 597  
731108**Power Setting Table — Lycoming Model O-540-A, 250 HP Engine**

Press. Alt. 1000 Feet	Std. Alt. Temp. °F	138 HP — 55% Rated Approx. Fuel 10.3 Gal./Hr. RPM AND MAN. PRESS.				163 HP — 65% Rated Approx. Fuel 12.3 Gal./Hr. RPM AND MAN. PRESS.				188 HP — 75% Rated Approx. Fuel 14.0 Gal./Hr. RPM AND MAN. PRESS.		
		2100	2200	2300	2400	2100	2200	2300	2400	2200	2300	2400
SL	59	21.6	20.8	20.2	19.6	24.2	23.3	22.6	22.0	25.8	25.1	24.3
1	55	21.4	20.6	20.0	19.3	23.9	23.0	22.4	21.8	25.5	24.8	24.1
2	52	21.1	20.4	19.7	19.1	23.7	22.8	22.2	21.5	25.3	24.6	23.8
3	48	20.9	20.1	19.5	18.9	23.4	22.5	21.9	21.3	25.0	24.3	23.6
4	45	20.6	19.9	19.3	18.7	23.1	22.3	21.7	21.0	24.8	24.1	23.3
5	41	20.4	19.7	19.1	18.5	22.9	22.0	21.4	20.8	—	23.8	23.0
6	38	20.1	19.5	18.9	18.3	22.6	21.8	21.2	20.6	—	—	22.8
7	34	19.9	19.2	18.6	18.0	22.3	21.5	21.0	20.4	—	—	—
8	31	19.6	19.0	18.4	17.8	—	21.3	20.7	20.1	—	—	—
9	27	19.4	18.8	18.2	17.6	—	—	20.5	19.9	—	—	—
10	23	19.1	18.6	18.0	17.4	—	—	—	19.6	—	—	—
11	19	18.9	18.3	17.8	17.2	—	—	—	—	—	—	—
12	16	18.6	18.1	17.5	17.0	—	—	—	—	—	—	—
13	12	—	17.9	17.3	16.8	—	—	—	—	—	—	—
14	9	—	—	17.1	16.5	—	—	—	—	—	—	—
15	5	—	—	—	16.3	—	—	—	—	—	—	—

To maintain constant power, correct manifold pressure approximately 0.17" Hg for each 10° F. variation in carburetor air temperature from standard altitude temperature. Add manifold pressure for air temperatures above standard; subtract for temperatures below standard.

THE PIPER COMANCHE

SECTION IV

SECTION V

GENERAL MAINTENANCE

Tire Inflation . . . . .	49
Battery Service . . . . .	49
Brake Service . . . . .	50
Landing Gear Service . . . . .	50
Fuel and Oil Requirements . . . . .	51
Leveling and Rigging . . . . .	51
Lubrication Chart . . . . .	53
Fuel Systems . . . . .	54
Care of Air Filter . . . . .	56
Care of Windshield and Windows . . . . .	57
Serial Number Plate . . . . .	57



## SECTION V

## MAINTENANCE

This section of the Comanche Handbook contains information which pertains to minor maintenance of the airplane. Any complex repair or modification should be accomplished by a Piper Certified Service Center or equivalent.

TIRE INFLATION

For maximum service from the tires on the Comanche, keep tires inflated to the proper pressure of 27 lbs. on all three tires on the Comanche 180, and 42 lbs. on the main wheels and 27 lbs. on the nose wheel on the Comanche 250. Interchange the tires on the wheels if necessary to produce even wear. All wheels and tires are balanced before original installation, and the relationship of tire, tube and wheel should be maintained whenever possible upon reinstallation. Out of balance wheels can cause extreme vibration in the landing gear during take-off. In the installation of new components, it may be necessary to rebalance the wheels with the tires mounted.

BATTERY SERVICE

Access to the 12-volt 33-ampere hour battery is through the right rear baggage compartment panel. The stainless steel box has a plastic drain tube which is normally closed off with a clamp and which should be opened occasionally to drain off any accumulation of liquid.

The battery should be checked frequently for proper fluid level, but must not be filled above the baffle plates. All connections must be clean and tight.

If the battery is not up to proper charge, recharge starting with a charging rate of 4 amps and finishing with 2 amps. Quick charges are not recommended.



### BRAKE SERVICE

The brake system is filled with MIL-H-5606 (petroleum base) hydraulic brake fluid. This should be checked at every 100 hour inspection and replenished when necessary, refilling the brake reservoir on the firewall to the indicated level.

No adjustment of brake clearances is necessary on the Comanche brakes. If after extended service the brake blocks become worn excessively, they are easily replaced with new brake segments.

Main wheels are easily removed by taking off the hub nut and withdrawing the axle bolt, the axle retainer cups, the axle, and remove four bolts from the brake assembly after which the wheels slip freely from the wheel fork.

Tires are dismounted from the wheels by deflating the tube, then removing the wheel through-bolts, allowing the wheel halves to be separated.

### LANDING GEAR SERVICE

In jacking up the Comanche for landing gear and other service, a jack kit (available through the Piper Aircraft Distributor Service Departments) should be used. This kit includes two hydraulic jacks and a tail support. Approximately 300 lbs. of ballast should be placed on the base of the tail support before jacking up the airplane.

Landing gear strut exposure should be measured with the airplane parked on a level surface and with all wing tanks full of fuel. The recommended exposures for all three gears are 2-3/4 inches on the PA-24-250 and 2-1/4 inches on the PA-24-180. Nose gear strut exposure may vary from 2-1/4 to 2-3/4 inches at the pilot's discretion.

To add air to the oleo struts, a strut pump is attached to the air valve and the oleo pumped to the proper position. To add oil, first

release the air through the valve, allowing the oleo to compress fully. Next remove the air valve core and fill the unit through this opening. Then compress the oleo to within 1/4 inch of full compression, allowing air and excess oil to escape. Then reinsert the valve core and inflate the strut to the proper position.

### FUEL AND OIL REQUIREMENTS

Aviation Grade 91/96 Octane (minimum) fuel must be used in the Comanche. The use of lower grades of fuel can cause serious engine damage in a very short period of time and is considered of such importance that the engine warranty is invalidated by such use.

The oil capacity of the Lycoming O-360-A is 8 quarts, and the minimum safe quantity is 2 quarts. For the O-540-A, the capacity is 12 quarts and the minimum safe quantity 2-3/4 qts. The operating oil level is normally kept a quart or more below the maximum to reduce oil consumption. It is recommended that engine oil be changed every 50 hours or sooner under unfavorable conditions. The following grades are required for the specified temperatures:

Temperatures above 40° F	S.A.E. 50
Temperatures between 10° F and 40° F	S.A.E. 30
Temperatures below 10° F	S.A.E. 20

### LEVELING AND RIGGING

Leveling the Comanche for purposes of reweighing or rigging is accomplished as follows:

(1) Partially withdraw two machine screws located on the side of the fuselage over the baggage door. These screws are leveling points and the airplane is longitudinally level when a level placed on the head of these

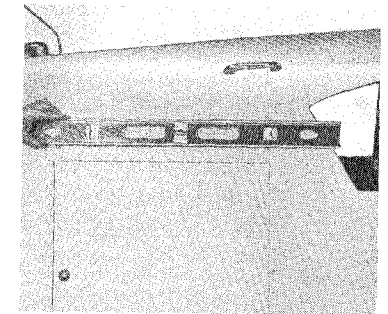

Longitudinally Level

TYPE OF LUBRICANTS			NOTES
IDENTIFICATION LETTER	SPECIFICATION	LUBRICANT	
A	MIL-L-7870	LUBRICATING OIL, GENERAL PURPOSE, LOW TEMP.	<p>1. WHEEL BEARINGS - REQUIRE CLEANING AND REPACKING AFTER EXPOSURE TO AN ABNORMAL QUANTITY OF WATER.</p> <p>2. SEE LYCOMING SERVICE INSTRUCTION NO. 1014 FOR USE OF DETERGENT OIL.</p> <p>3. MISCELLANEOUS - DURING ROUTINE MAINTENANCE CHECKS, APPLY LUBRICANT TO MISCELLANEOUS LINKAGES.</p> <p>4. REFER TO SERVICE LETTER NO. 361 FOR LUBRICATION REQUIREMENTS.</p> <p>5. DEPENDING ON EXISTING CONDITIONS, IT MAY BE NECESSARY TO CLEAN THE FILTER DAILY OR EVERY FIVE HOURS.</p> <p>6. FUEL SELECTOR VALVE - WHEN OVERHAULING FUEL SELECTOR VALVE, PACK O-RINGS WITH "PETROLATUM," PURE OIL CO. CODE NO. 9605.</p> <p>7. TRANSMISSIONS SHOULD BE DISASSEMBLED, CLEANED, INSPECTED, AND LUBRICATED AT EACH 500 HOUR INTERVAL OR ANNUALLY. ACTUATOR SCREWS SHOULD BE LUBRICATED AT EACH 100 HOUR INTERVAL OR ANNUALLY.</p>
B	MIL-L-8082	LUBRICATING OIL, AIRCRAFT RECIPROCATING ENGINE (PISTON) GRADE AS SPECIFIED SAE 50 ABOVE 60°F AIR TEMP. SAE 40 30° TO 90°F AIR TEMP. SAE 30 0° TO 70°F AIR TEMP. SAE 20 BELOW 10°F AIR TEMP.	
C	MIL-H-5606	HYDRAULIC FLUID, PETROLEUM BASE	
D	MIL-G-23827	GREASE, AIRCRAFT AND INSTRUMENT, GEAR AND ACTUATOR SCREW	
E	MIL-G-3546	GREASE, AIRCRAFT, HIGH TEMPERATURE	
F	...	ALL PURPOSE SLIP SPRAY DUPONT NO. 6611	
G	MIL-G-6032	GREASE, PLUG VALVE, GASOLINE AND OIL RESISTANT	

**SPECIAL INSTRUCTIONS**

- CLEANING AND SERVICING AIR FILTER - REFER TO SERVICE MANUAL, POWER PLANT SECTION, FOR APPROPRIATE FILTER AND INSTRUCTIONS. SEE NOTE 5.
- BEARINGS AND BUSHINGS - CLEAN EXTERIOR WITH A DRY TYPE SOLVENT BEFORE RELUBRICATING (EXCEPT SEALED BEARINGS).
- LANDING GEAR AND FLAP TRANSMISSIONS AND SCREWS, IDENTIFY TYPE OF TRANSMISSION INSTALLED. DUKES HAS LABEL ON TRANSMISSION HOUSING, DURA HAS PART NO. 1010250 STAMPED ON TRANSMISSION HOUSING. DISASSEMBLE AND CLEAN WITH A QUICK DRYING TYPE SOLVENT. WHEN REASSEMBLING TRANSMISSIONS, FILL DUKES TRANSMISSION WITH DUKES NO. 4 LUBRICANT OR DURA TRANSMISSION WITH MIL-G-7118 OR MIL-G-23827 GREASE. NO SUBSTITUTION IS ALLOWED IN EITHER TRANSMISSION. APPLY A THIN COAT OF MIL-G-7118 OR MIL-G-23827 GREASE ON ACTUATOR SCREWS. SEE NOTE 6.
- OLEO STRUTS AND BRAKE RESERVOIR - FILL PER INSTRUCTIONS ON UNIT OR CONTAINER, OR REFER TO SERVICE MANUAL SECTION II.
- PROPELLER - REMOVE ONE OF THE TWO GREASE FITTINGS FOR EACH BLADE. APPLY GREASE THROUGH FITTING UNTIL FRESH GREASE APPEARS AT HOLE OF REMOVED FITTING. NOTE: McCauley PROPELLERS ARE PRELUBRICATED AND REQUIRE NO LUBRICATION UNTIL DISASSEMBLY.
- LUBRICATION POINTS - WIPE ALL LUBRICATION POINTS CLEAN OF OLD GREASE, OIL, DIRT, ETC., BEFORE RELUBRICATING.
- LUBRICATE FLAP TRACK WITH DUPONT'S ALL PURPOSE SLIP SPRAY NO. 6611. FLAP ROLLERS AND TRACKS REQUIRE CLEANING AND LUBRICATION AFTER EXPOSURE TO AN ABNORMAL QUANTITY OF WATER. FLAPS WITH NYLON ROLLERS WILL NOT REQUIRE LUBRICATION ON EITHER FLAP TRACKS OR ROLLERS. FOR LUBRICATION OF EARLY MODELS WITH FLAP HINGES, REFER TO SKETCH C.
- OVERHEAD TRIM PULLEYS - LUBRICATION MAY BE EXTENDED TO 250 HOURS WHEN DUSTY CONDITIONS ARE AT A MINIMUM. SEE CAUTION 4.
- THREE POSITION FUEL SELECTOR VALVE - LUBRICATE AS REQUIRED. SEE NOTE 4.
- FIVE POSITION FUEL SELECTOR VALVE - LUBRICATE DURING OVERHAUL OF VALVE. SEE NOTE 6.

  

**CAUTIONS**

- DO NOT USE HYDRAULIC FLUID WITH A CASTOR OIL OR ESTER BASE.
- DO NOT OVER-LUBRICATE COCKPIT CONTROLS.
- DO NOT APPLY LUBRICANT TO RUBBER PARTS.
- UNDER NO CIRCUMSTANCES SHOULD THE CABLES FROM THE COCKPIT TO THE REAR OF THE FUSELAGE BE LUBRICATED, AS THIS MAY CAUSE SLIPPAGE.
- REMOVE ALL EXCESS GREASE FROM GREASE FITTINGS.

**EXAMPLE**



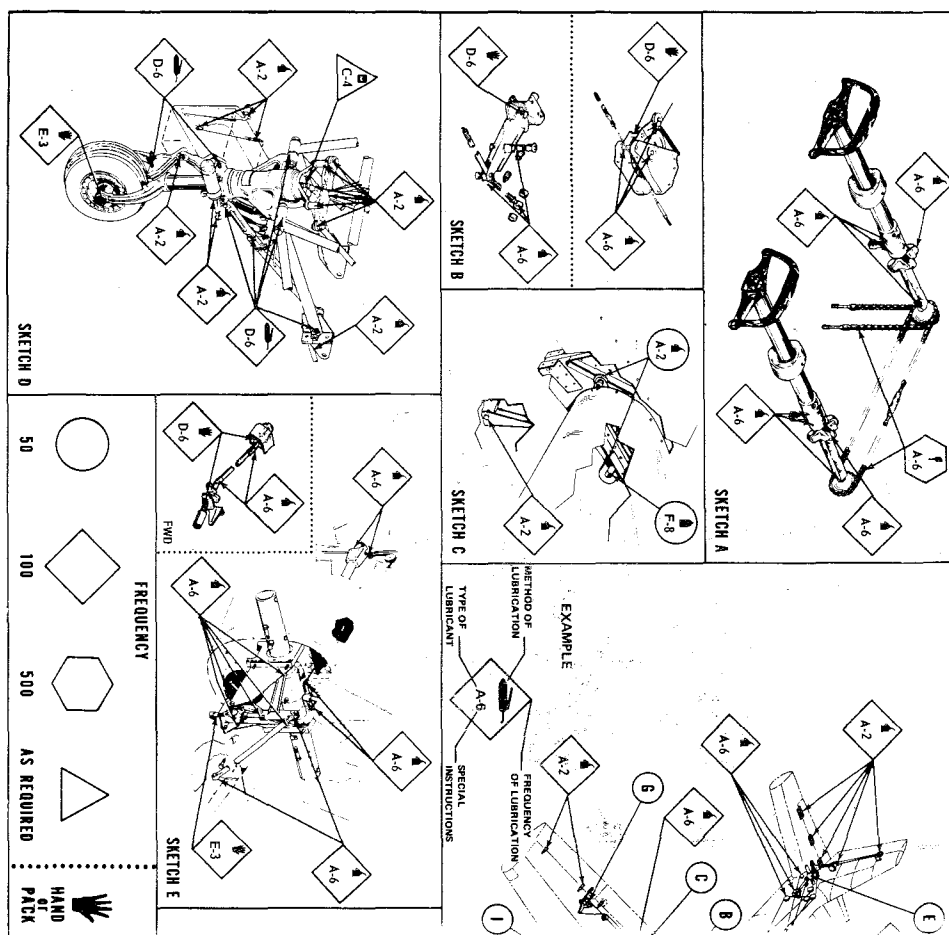

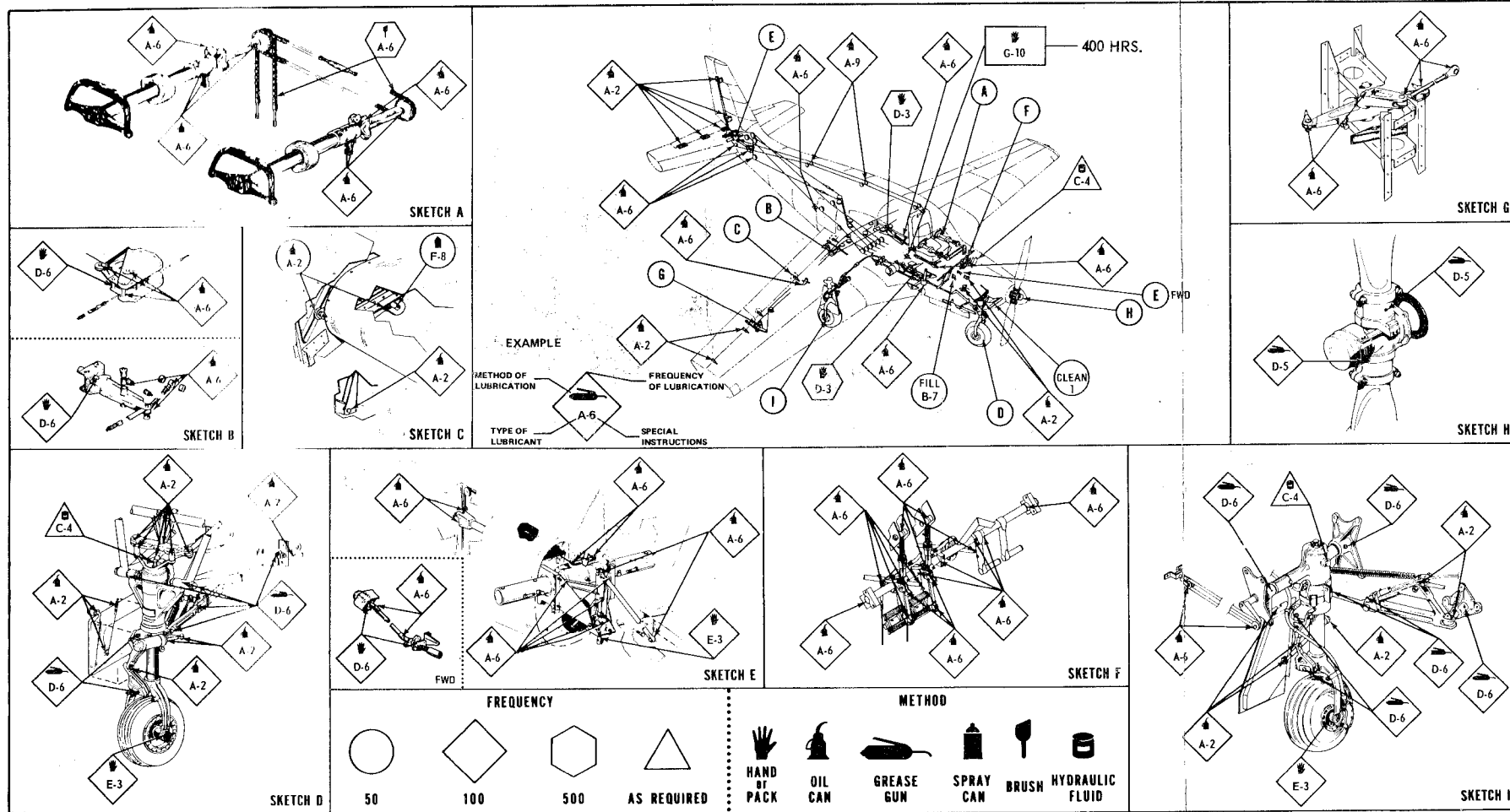
SPECIAL INSTRUCTIONS

8. OVERHEAD TRAVEL PULLEYS - LUBRICATION MAY BE EXTENDED TO 200 HOURS WHEN IN "DOWN" POSITION. SEE NOTE 9.

9. THREE POSITION FUEL SELECTOR VALVE - LUBRICATE AS REQUIRED. SEE NOTE 4.

10. FIVE POSITION FUEL SELECTOR VALVE - LUBRICATE DURING OVERHAUL OF VALVE. SEE NOTE 6.

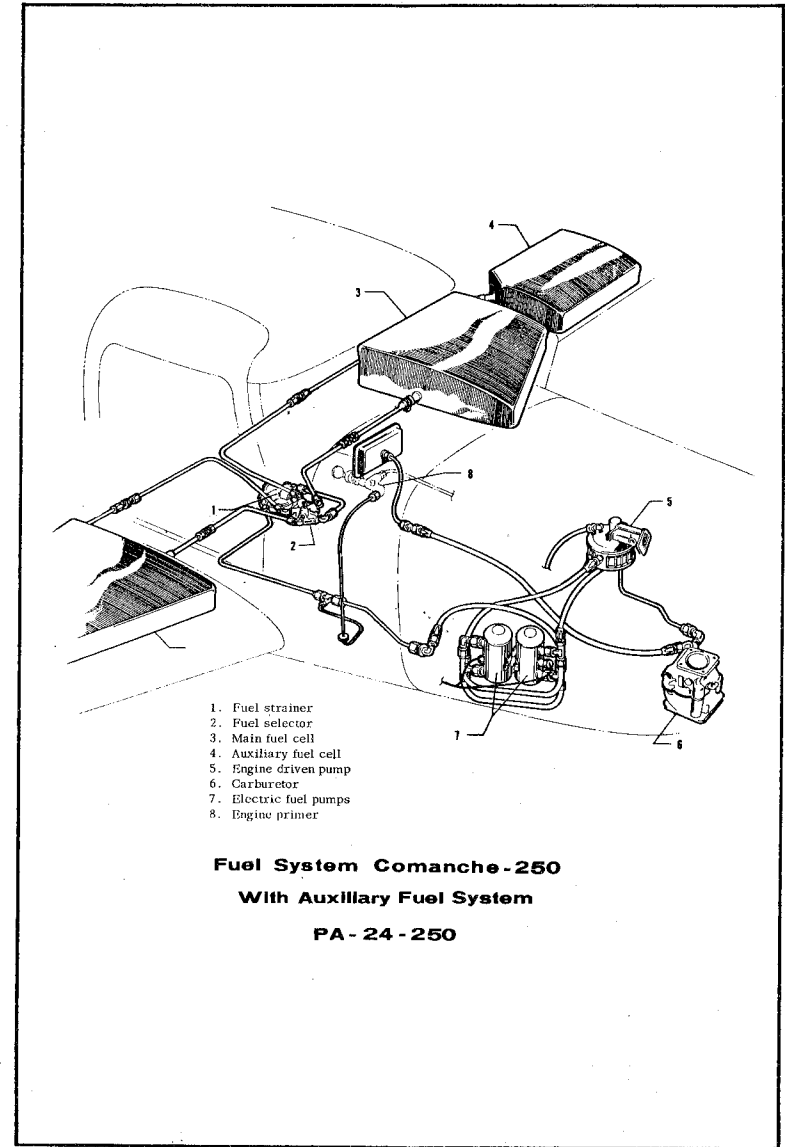
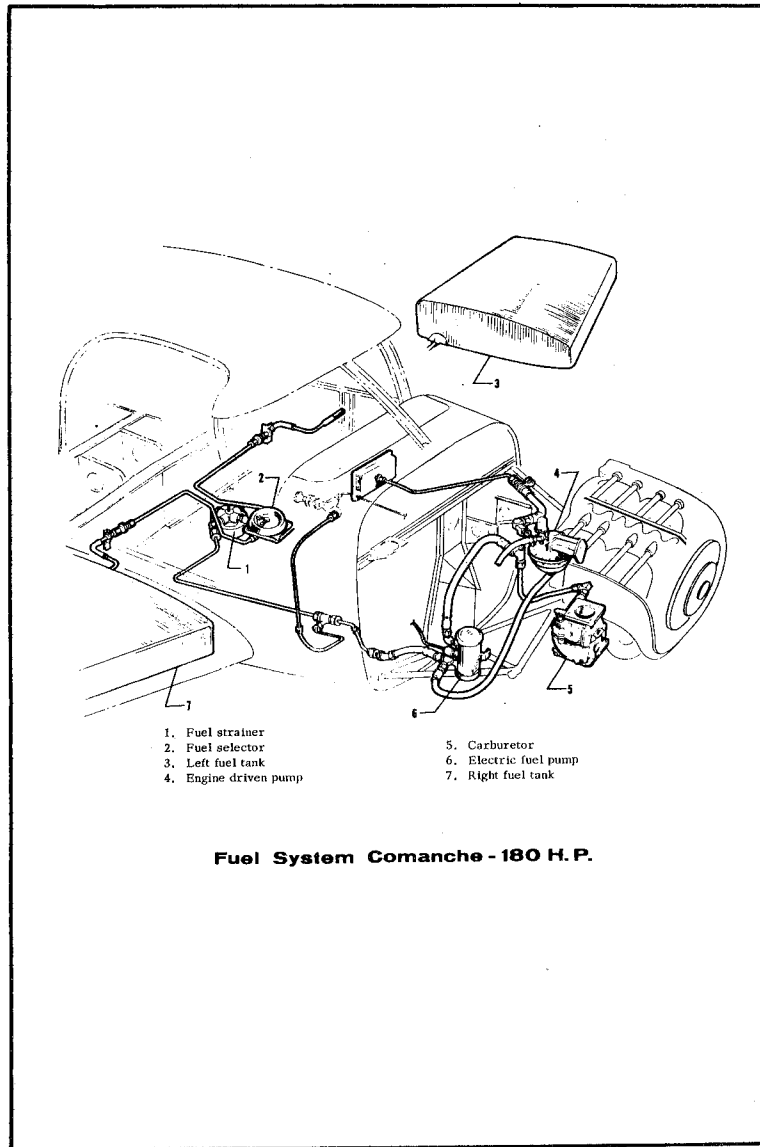

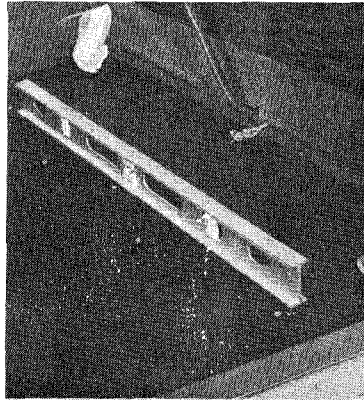

Laterally Level

screws indicates level.

(2) To put the airplane in a longitudinally level position on scales, first block the main gear oleos to full extension, then deflate the nose wheel tire until the proper position is reached. For rigging purposes only, place airplane on jacks.

(3) To level the airplane laterally, place a level across the floorboard at station 136.5 bulkhead (in baggage compartment between rear spar attachment points).

Rigging: Although the fixed flight surfaces on the Comanche obviously cannot be adjusted in position for rigging purposes, it may be necessary on occasion to check the position of these surfaces. The movable surfaces, with the exception of the flaps, all have adjustable stops as well as adjustments on their cables or push-pull connections so that their range of movement can be altered. The positions and travels of the various surfaces are as follows:

- (1) Wings:  $5^{\circ}$  dihedral, no twist.
- (2) Stabilator: No dihedral, travel - PA-24-180  $13^{\circ}$  up,  $5^{\circ}$  down,  $+1^{\circ}$ ; PA-24-250  $14^{\circ}$  up,  $4^{\circ}$  down,  $+1^{\circ}$ .
- (3) Fin: Should be vertical and in line with center of fuselage.
- (4) Ailerons: Travel  $19^{\circ}$  up,  $15^{\circ}$  down,  $+1^{\circ}$ .
- (5) Flaps: Travel - PA-24-180  $27^{\circ}$  down in three  $9^{\circ}$  increments; PA-24-250  $32^{\circ}$  down.
- (6) Rudder: Travel  $25^{\circ}$  left or right,  $+2^{\circ}$ .

For purposes of changing the lateral trim, a fixed tab is provided on the left aileron which can be adjusted as necessary.

#### CARE OF AIR FILTER

The carburetor air filter must be cleaned at least once

every fifty hours and depending on the type of condition existing, it may be necessary to clean the filters daily or every five hours. Extra filters are inexpensive and should be kept on hand and used for rapid replacement.

The following cleaning procedure is recommended by the manufacturer of the filter:

- (1) Remove air scoop.
- (2) Remove filter from cowling.
- (3) Tap gently to remove dirt particles. Do not use compressed air.
- (4) Reassemble to cowling and replace scoop.

#### CARE OF WINDSHIELD AND WINDOWS

A certain amount of care is required to keep the plexiglas windows clean and clear. The following procedure is recommended:

- (1) Flush with clean water and dislodge excess dirt, mud, etc., with your hand.
- (2) Wash with mild soap and warm water. Use a soft cloth or sponge. (Do not rub.)
- (3) Remove oil, grease or sealing compounds with a cloth soaked in kerosene.
- (4) After cleaning, apply a thin coat of hard polishing wax. Rub lightly with a soft dry cloth.
- (5) A severe scratch or mar can be removed by using jeweler's rouge to rub out scratch, smooth on both sides and apply wax.

#### SERIAL NUMBER PLATE

The serial number plate on the Comanche is located on the inside of the baggage door. The serial number of the plane should always be used in referring to the airplane in service or warranty matters.

## INDEX

	Page
<b>SECTION I</b>	
Specification Features . . . . .	1
Power Plant . . . . .	1
Performance . . . . .	1
Weights . . . . .	2
Fuel . . . . .	3
Baggage . . . . .	3
Dimensions . . . . .	4
Landing Gear . . . . .	4
<b>SECTION II</b>	
Design Information . . . . .	5
Engine and Propeller . . . . .	5
Structures . . . . .	6
Landing Gear . . . . .	6
Control System . . . . .	9
Fuel System . . . . .	10
Electrical System . . . . .	12
Heating and Ventilating System . . . . .	13
Instrument Panel . . . . .	15
Baggage Compartment . . . . .	16
Seats . . . . .	17
<b>SECTION III</b>	
Operating Instructions . . . . .	18
Preflight . . . . .	18
Starting Engine . . . . .	19
Warm-up and Ground Check . . . . .	20
Takeoff . . . . .	21
Climb . . . . .	24
Cruising . . . . .	25
Stalls . . . . .	26
Emergency Procedures . . . . .	30
Manual Gear Extension . . . . .	30
Gear-up Landing . . . . .	32

# THE PIPER COMANCHE

## INDEX (cont)

	Page
Engine Failure . . . . .	32
Mooring . . . . .	32
Operating Tips . . . . .	33
Weight and Balance . . . . .	33b

### SECTION IV

Performance Charts . . . . .	34
Altitude Conversion Chart . . . . .	34
Takeoff Performance - PA-24-180 . . . . .	35
Takeoff Performance - PA-24-250 . . . . .	36
True Airspeed vs Density Altitude - PA-24-180 . . . . .	37
True Airspeed vs Density Altitude - PA-24-250 . . . . .	38
Range vs Density Altitude - PA-24-180 . . . . .	39
Range vs Density Altitude - PA-24-250 . . . . .	40
Rate of Climb vs Density Altitude - PA-24-180 . . . . .	41
Rate of Climb vs Density Altitude - PA-24-250 . . . . .	42
Landing Performance - PA-24-180 . . . . .	43
Landing Performance - PA-24-250 . . . . .	44
Power Chart - Lycoming O-360-A . . . . .	45
Power Chart - Lycoming O-540-A1D5 . . . . .	46
Power Setting Table - Lycoming Model O-360-A . . . . .	47
Power Setting Table - Lycoming Model O-540-A . . . . .	48

### SECTION V

General Maintenance . . . . .	49
Tire Inflation . . . . .	49
Battery Service . . . . .	50
Brake Service . . . . .	50
Landing Gear Service . . . . .	50
Fuel and Oil Requirements . . . . .	51
Leveling and Rigging . . . . .	51
Lubrication Chart . . . . .	53
Fuel Systems . . . . .	54
Care of Air Filter . . . . .	56
Care of Windshield and Windows . . . . .	57
Serial Number Plate . . . . .	57